

WILDLIFE
ACOUSTICS



See Page 1 for
Quick Start Guide

SMART

Song Meter with Analysis and Remote Transfer

User Guide

Last updated on April 9, 2024

TABLE OF CONTENTS

1	Quick Start Guide	1
2	What's in the Box?	2
3	Overview	4
3.1	Song Meter with Analysis and Remote Transfer	4
3.2	SMART Linux Resources Guide	4
3.3	Technology	4
3.4	Updates	4
4	SMART Controller	5
4.1	Overview	5
4.2	Power Requirements	6
4.3	SMART Controller Processing Limitations	7
4.4	File Storage	7
4.5	Installation Notes	7
5	SMART MIC-1	9
5.1	Overview	9
5.2	Ultrasonic Sensors	10
5.3	Ultrasonic Speaker and Calibration	10
5.4	Heater	12
5.5	Mounting Bracket	12
5.6	Cable Connection Instructions	17
5.7	Example Configurations	21
6	Connection to the SMART System	24
6.1	Direct Keyboard and Monitor	24
6.2	Network Configuration	24
6.3	WIFI	25
6.4	RJ45 Ethernet	26
6.5	Serial	26
7	SMART Web Interface	27
7.1	Connect To The SMART Web Interface	27
7.2	Devices Tab	28
7.3	Data Files Tab	30
7.4	Settings Profiles Tab	32
7.5	Schedule Profiles Tab	40
7.6	Time and Location Tab	44
7.7	Serial Output Tab	45
7.8	SCADA Tab	47
7.9	Networking Tab	54
7.10	Maintenance Tab	58
7.11	Administration Tab	61
8	SMART Internet Gateway	63
8.1	Connect the SMART System to the Internet	63
8.2	Configure the SMART System for Internet Gateway connection	65
8.3	Configure Gateway access through WildlifeAcoustics.com	66
9	OPC UA Communications Interface	68
9.1	OPC UA Introduction	68
9.2	OPC UA Installation	68
9.3	OPC UA Configuration	68
9.4	Connecting to the OPC UA Interface	69
9.5	SMART Controller Information Model	70

9.6 OPC UA Events	73
10 Network Security	73
10.1 SMART System	73
10.2 Wildlife Acoustics IOT Gateway.....	74
11 Specifications	74
11.1 SMART Controller Specifications	74
11.2 SMART Controller Dimensions.....	75
11.3 SMART Controller Power Specifications	75
11.4 SMART MIC-1 Dimensions	76
11.5 SMART MIC-1 Audio Specifications.....	77
12 Additional Resources	78
12.1 Common Linux Command Lines.....	78
12.2 Serial Port Configuration	79
12.3 Bat Analysis Statistics	79
13 Terms Of Use	80
14 Warranty and Disclosures	81

Revised and Translated User Guides

This guide is regularly updated and improved. New versions can be downloaded from:
<http://www.wildlifeacoustics.com/support/documentation>.

Tutorial Videos (not yet online)

Visit www.wildlifeacoustics.com/support/tutorial-videos to view tutorial videos for the SMART System.

Technical Support

For technical queries contact the Wildlife Acoustics support team:

<https://www.wildlifeacoustics.com/contact-us>

North America (toll-free): 1-888-733-0200

Outside North America (toll charges may apply): +1 978-369-5225

Don't miss out on Important Updates

We continually add features to the SMART System. Stay up to date with the newest features and receive important technical support bulletins by signing up to our mailing list at:

<http://www.wildlifeacoustics.com/products#mailinglist>

1 Quick Start Guide

This section describes first-time access to the SMART System.

- This Quick Start procedure is based on the default out-of-the-box configuration of the SMART System.
- The core component of a SMART System is the SMART Controller.
- The SMART System can be configured, monitored, and controlled, via a web browser interface.
- The SMART Web Interface is served from the SMART Controller.

NOTE: This Quick Start is based on initial access of the system through the web interface option. The SMART Web Interface is not the only method for monitoring and controlling the SMART system.

- The SMART Controller is pre-configured to generate a local area network WIFI HotSpot.
 - Any device with built-in WIFI and the ability to run a web browser can be used for initial connection to the SMART System.
1. Connect the antennae to the SMART Controller.
 2. Connect a power supply to the SMART Controller.
 - The SMART Controller ships with an AC power adapter.
 - Other power sources can be used as long as they meet the SMART Controller power specifications.
 3. The SMART Controller will power on automatically. There is no need to press the Power button.
 - Initial system boot-up could take up to two minutes.

NOTE: If power is ever interrupted, the SMART Controller will automatically restart when power is restored.

- In default configuration, the SMART Controller will automatically generate a WIFI HotSpot access point when powered on.
 - The SSID of the default SMART System access point is: "smart (plus the internal serial number of the SMART Controller)".
4. Connect to the SMART WIFI network from a WIFI-enabled laptop, PC, tablet, or phone.
 - A window will open asking for the WPA2 password.
 - The default SMART network password is "wildlife".
 5. Open a web browser and enter this URL: <https://192.168.19.1/>
 - The browser will display a series of messages about not trusting the SSL/TLS certificate and other security concerns.
 - Connect anyway. This is a secure network.
 6. A window will appear to enter a username and password.
 - The default username is "smart".
 - The default password is "wildlife".
 7. The SMART Web Interface will now be displayed.
 - All user functions of the SMART System, including any connected SMART MIC-1 microphone devices, are now accessible.

SMART Controller is WIFI HotSpot (Default configuration)



2 What's in the Box?

The core SMART system ships with the following components:

- SMART Controller CPU
- Rubber stick-on feet
- WIFI antennas (2)
- AC power adapter
 - This provides DC power to the SMART controller from an AC power source. If the SMART Controller is powered via some other DC source, the AC power adapter is not used
- Power cable for AC adapter (connector type based on local standard)
- Screw-down terminal connector
 - (Shown in plastic bag) This provides screw terminals for external DC power connection to the SMART Controller
- Display Port to HDMI adapter cable



MIC-1

Each MIC-1 ships with the following:

- In-Line RJ45 Surge Suppressor
- RJ45 Cable Gland (Waterproof Connection Part)
- Cable Ferrite, including two zip-ties to hold in position (For RF rejection)
- 30cm RJ45 Ethernet Patch Cable



3 Overview

3.1 Song Meter with Analysis and Remote Transfer

- The Wildlife Acoustics SMART System is a flexible multi-channel acoustic analysis platform designed for advanced applications.
- The first offering of the SMART System is designed and optimized for the needs of wind farm operators for real-time bat monitoring and smart curtailment.
- The SMART System offers a range of options for remote real-time monitoring and control, as well as download of recording files and other data.
- Kaleidoscope Pro technology is built into the SMART System. This provides real-time analysis, including:
 - Detection of bat echolocation pulses
 - Adaptive audio-based triggering
 - Analysis and scrubbing of false trigger signals
 - Call feature extraction
 - Bat species auto-ID
 - Audio file compression
- The basic physical components of a Wildlife Acoustics SMART System currently include the [SMART Controller](#), connection cables and power source, and at least one [SMART MIC-1](#) microphone device.
- Up to three SMART MIC-1 microphone devices can be connected to the base model SMART Controller.

3.2 SMART Linux Resources Guide

Additional Linux reference resources are provided for the SMART system. These resources are found in the accompanying SMART Linux Resources Guide.

3.3 Technology

- The SMART System incorporates Wildlife Acoustics proprietary technology (license required) on an open platform with additional open source components available from Wildlife Acoustics.
- Open source PHP scripts and other pieces provide a web-based user interface to the SMART System.
 - The SMART Web Interface and use of the SMART library functions can be customized to support a wide range of applications and integrations.
 - The proprietary technology comprises the SMART Internet Gateway, the SMART Daemon, a background privileged process used to communicate with the SMART Devices, and the SMART library. The SMART library includes functions which allow for building custom applications and integrations.
 - Open-source contributions are provided which link with the SMART library. These include command line programs smart-list, smart-ctl, smart-stream, etc., as described in the SMART Linux Resources document.
- Because Linux is an open-source platform, the SMART System is compatible with a wide range of external commercially available and open-source hardware and software solutions. External systems can be integrated with the SMART System and customized to suit a variety of needs. Examples include integration with:
 - Wind farm SCADA Systems
 - Third-party weather stations
 - TCP/IP networks over cellular modems

3.4 Updates

- The SMART System can be updated by downloading and applying a software package update file.
- The SMART System update may or may not include a firmware update for the SMART MIC-1 Device (Or other Device models in the future).
- A SMART System software package update is applied under the [Administration tab](#) in the SMART Web Interface.

4 SMART Controller



4.1 Overview

The physical core of a SMART System is an industrial Ubuntu Linux-based computer, which is described as the SMART Controller.

- The SMART Controller ships with the SMART System software installed, and default settings pre-configured.
- The SMART Controller is configured to automatically boot up when power is applied (there is no need to push the button to power on).

The following diagram describes possible physical connections to the SMART Controller. Connections in red are required. All other connections are optional:

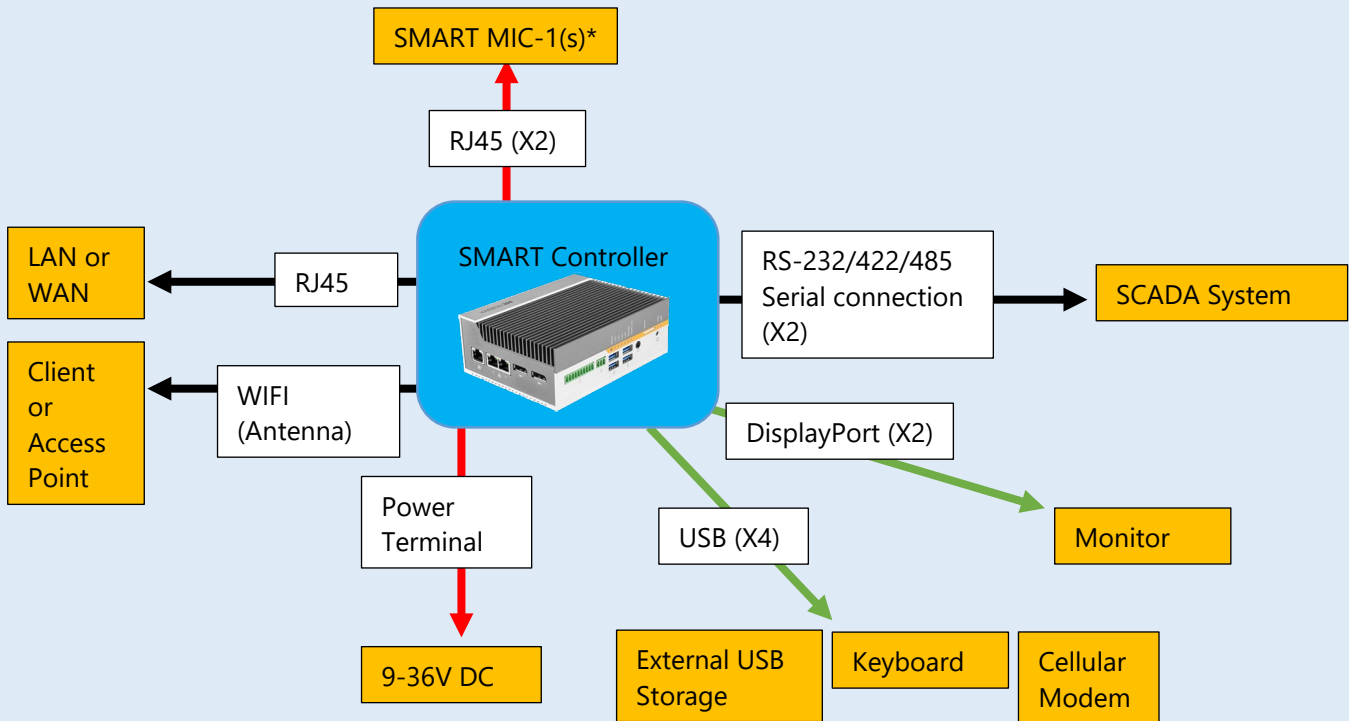

* For additional connection diagrams and information for Mic-1 and PoE connection see: [Example SMART MIC-1 Configurations](#)

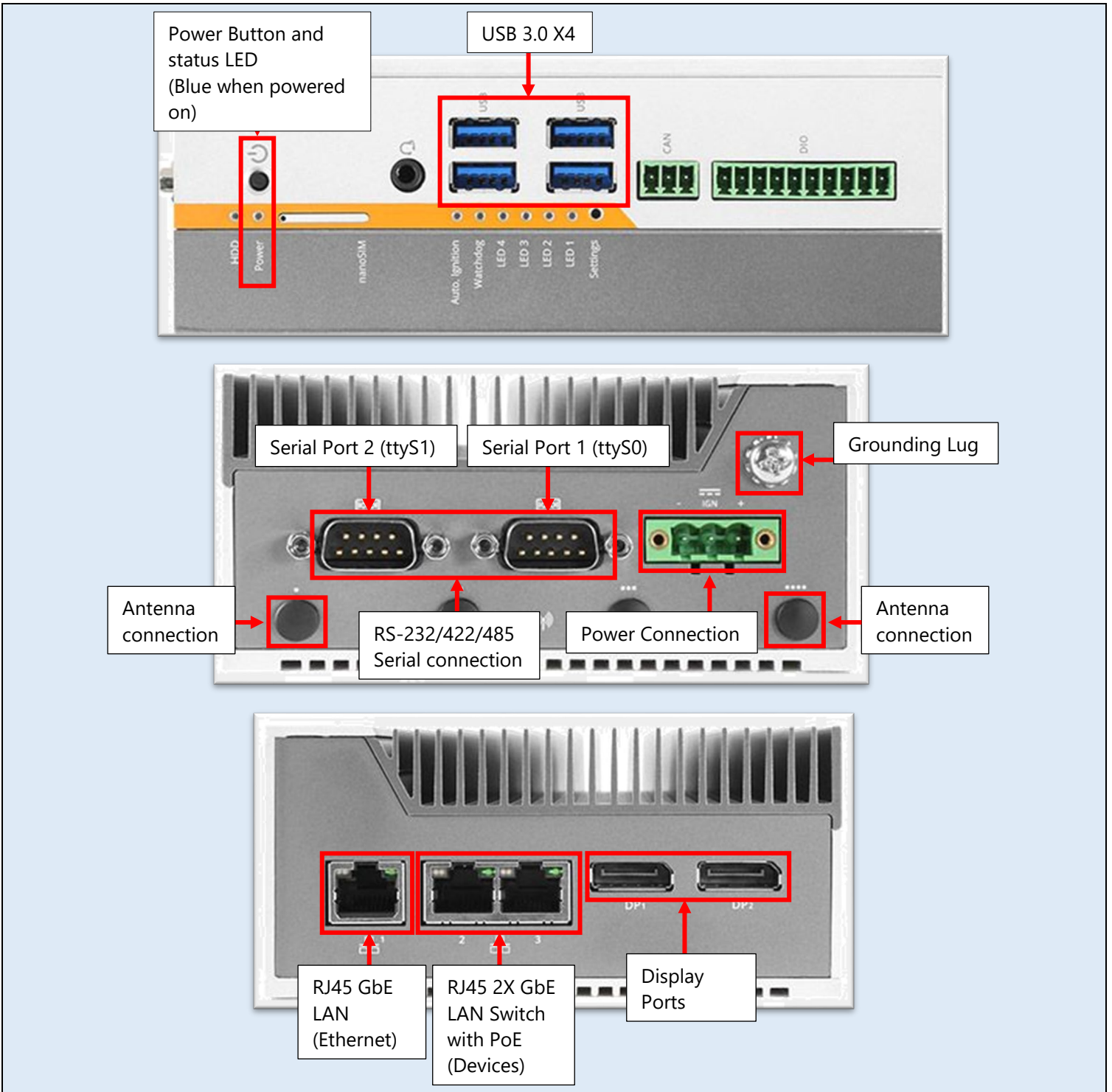

4.2 Power Requirements

The SMART Controller requires 9-36V DC power.

- The SMART Controller is configured to automatically boot up when power is applied (there is no need to push the button to power on).
- If power is interrupted, the SMART Controller will automatically reboot and resume operation again when power is restored.
- It takes one to two minutes for the SMART Controller to boot up into an operational state.
- It is recommended that the SMART Controller be powered down by pressing and holding the power button, and waiting for the power LED to turn off before disconnecting external power.
- A standard 100-240V AC 50-60Hz to 24V DC adapter is included with the SMART Controller.

- Other power sources can be used for the SMART Controller as long as they meet the specified requirements.
- Actual power consumption will vary based on attached peripherals, CPU load, system configuration, and other factors.

The following table illustrates typical power consumption in watts in various scenarios:

Configuration and Activity	Watts
Powered down	0.6
Idle, no PoE microphones attached	6.4
Idle, one PoE microphone attached	8.4
Streaming and analyzing one microphone	9.5
Idle, two PoE microphones attached	10.4
Streaming and analyzing two microphones	12.2
Streaming and analyzing three microphones*	14.5
Streaming and analyzing one microphone, heater enabled	15.2
Streaming and analyzing two microphones, heaters enabled	17.9
Streaming and analyzing three microphones, heaters enabled*	20.2

*Does not include power for necessary PoE switch.

NOTE: Additional hardware such as external SDD drives will consume additional power.

4.3 SMART Controller Processing Limitations

The base model 2-core 4GB version of the SMART Controller has tested processing limitations. The basic specifications can be expanded.

- Up to 3 SMART MIC-1 devices can be connected to a single SMART Controller
 - 1 SMART MIC-1 device is supported up to 500 kHz sample rate
 - 1-2 SMART MIC-1 devices are supported up to 384 kHz sample rate
 - 1-3 SMART MIC-1 devices are supported up to 256 kHz sample rate. (External PoE switch required for additional ports)

NOTE: If these limitations are exceeded, there may be drop-outs in the recordings (e.g. missing time and phase discontinuities).

4.4 File Storage

The SMART Controller ships with an internal 64 GB hard drive. It is possible to upgrade the internal drive to a larger size. It is also possible to connect a single external USB hard drive.

- The SMART System initially writes files to the internal drive. If the internal hard drive becomes 95% full, SMART will continue to run its schedule including analysis, writing to Modbus alarm registers, and log files.
- When an external USB hard drive is connected, configuration of what is copied to the external drive is done under the Maintenance tab.
- When an external hard drive is configured it will record files until it is full, including when the internal drive is full.
- The Maintenance tab is used to manage file rotation and deletion, and these settings apply to both internal and external drives.

4.5 Installation Notes

- The SMART Controller ships with SMART system software installed and default settings preconfigured.
- The SMART Controller is configured to automatically boot up when power is applied (there is no need to push the button to power on).
- If power is interrupted, the SMART Controller will automatically reboot and resume operation again when power is restored.
- It takes one to two minutes for the SMART Controller to boot up into an operational state.
- It is recommended that the SMART Controller be powered down by pressing and holding the power button, and waiting for the power LED to turn off before disconnecting external power.
- A standard 100-240V AC 50-60Hz to 24V DC adapter is included with the SMART Controller.

Grounding

- When the SMART Controller is deployed it should be properly grounded.
- Use the Grounding Lug to connect the SMART Controller to a secure ground point.

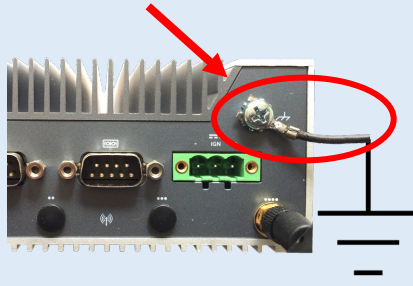

5 SMART MIC-1

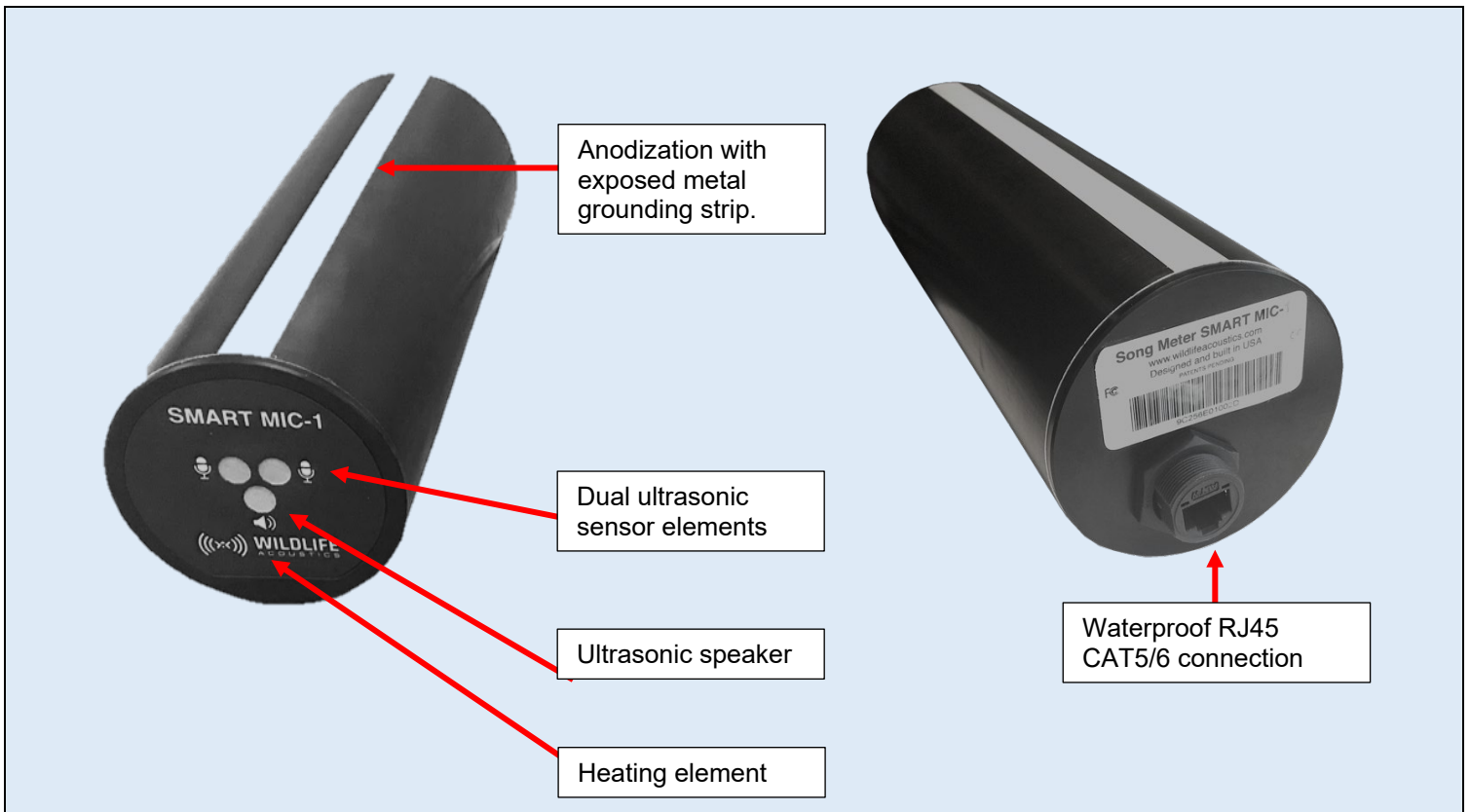

5.1 Overview

The SMART MIC-1 is a microphone system designed for monitoring and recording of bats. It is the first microphone available for the SMART System.

The SMART MIC-1 features:

- Enclosure is an IP67 weatherproof aluminum cylindrical housing
- Powered over Ethernet (PoE) either by direct connection to the SMART Controller or from a PoE switch or injector
- Streams audio to the SMART Controller for real time analysis and/or storage as wav or zc recording files
- Communicates with the SMART Controller using an Ethernet protocol developed by Wildlife Acoustics

This protocol features:

- Automatic discovery
- Time synchronization
- Configuration
- Efficient transfer of audio data for real time analysis and/or storage as wav or zc recording files
- On a 100Mbps Ethernet LAN, the SMART System can theoretically support up to 6 million samples per second across all microphone Devices.

The SMART MIC-1 is comparable to the SMM-U2 microphone used with the Wildlife Acoustics SM4BAT FS.

- Settings for gain, filters, etc., as well as frequency response and self-noise are identical.

Up to 3 SMART MIC-1 devices can be connected to a single SMART Controller.

- 1 SMART MIC-1 device is supported up to 500 kHz sample rate.
- 1-2 SMART MIC-1 devices are supported up to 384 kHz sample rate.
- 1-3 SMART MIC-1 devices are supported up to 256 kHz sample rate.

The SMART MIC-1 is typically configured and controlled via the [SMART Web Interface](#).

- All SMART MIC-1 parameters are configured within a [Settings Profile](#).
- A Settings Profile is assigned to a SMART MIC-1 under the [Devices tab](#).
- SMART MIC-1 Device activity is determined by a [Schedule Profile](#).
- A Schedule Profile is assigned to a SMART MIC-1 under the Devices tab.

5.2 Ultrasonic Sensors

The SMART MIC-1 features two built-in Ultrasonic Sensors (microphones).

- Two sensors provide redundancy for added reliability.
- A single Ultrasonic Sensor is in use at a time.
- The SMART MIC-1 will automatically switch between sensors based on programmed calibration testing.

NOTE: The Ultrasonic Sensors have a cardioid pickup pattern, therefore the front of the SMART MIC-1 should be pointed towards the expected source of sound.

5.3 Ultrasonic Speaker and Calibration

The SMART MIC-1 features an Ultrasonic Speaker, located between the two Ultrasonic Sensors. The Ultrasonic Speaker is used to generate a signal which is used to measure the sensitivity of each Ultrasonic Sensor. The SMART MIC-1 will then switch to the sensor with the better measurement.

- The calibration functions are configured within a [Settings Profile](#).
- A Device Profile determines if and when the calibration will be activated within the currently assigned Schedule Profile.
- Calibration is run periodically during the recording schedule. (The default setting is once per hour).
- Calibration takes approximately 2 seconds.
- The Ultrasonic Speaker emits a 40 kHz tone at a specified amplitude.
- The SMART System measures the sensitivity of each Ultrasonic Sensor.
- The sensitivity measurements are compared to the Calibration Target.
- The Calibration Target is nominal. The sensor which measures closest to nominal is selected for recording.
- The SMART MIC-1 then switches audio streaming to the Ultrasonic Sensor which measures closest to the Calibration Target.
- The selected Ultrasonic Sensor will be used until the next time the calibration is activated.

NOTE: The MIC-1 does not record during the calibration

Calibration results are stored in the log.txt file. The log.txt file shows:

- Measured sensitivities for the primary/secondary sensors
- Which sensor was selected as the closest to -25 (nominal)

The selected sensor is also indicated in the metadata of recording files.

Run an Immediate Sensor Calibration Test

In general, the intention of the calibration test is that it is done periodically as assigned in a Settings Profile. For example, the default Settings Schedule runs the calibration test once per hour. The results of each calibration are stored to the log.txt file. When any calibration period is assigned in a Settings Profile, the calibration test will always be run when the schedule is initiated. Therefore, if the schedule starts on the hour, the calibration test is done at the start of the hour.

- It is possible to cause the SMART system to run an immediate calibration test.

1. Check that Calibration Period is specified in a Settings Profile.

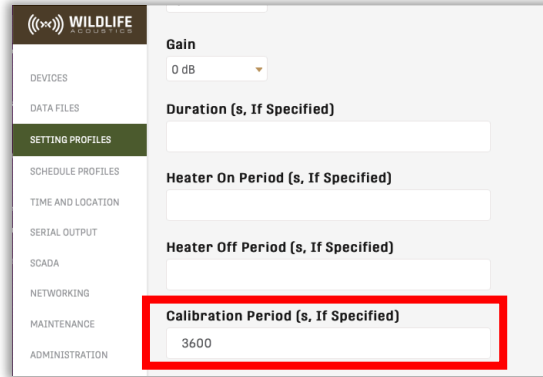

2. Check that the Settings Profile is currently assigned to the MIC-1 in the Devices tab.

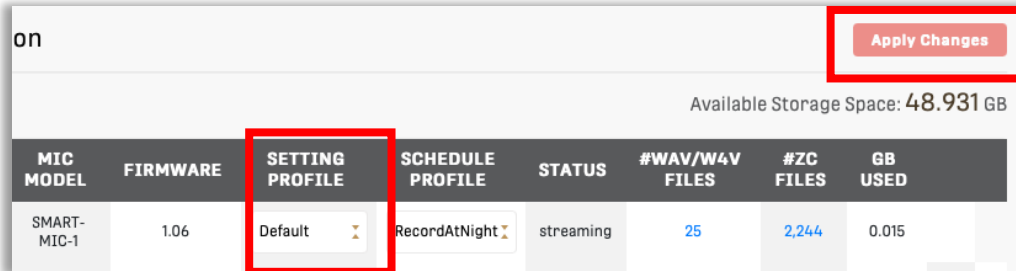

3. If any Schedule Profile is currently assigned, choose Disabled.

4. Press the Apply Changes button.

This will stop any current schedule and the MIC-1 will be listed as Disabled.

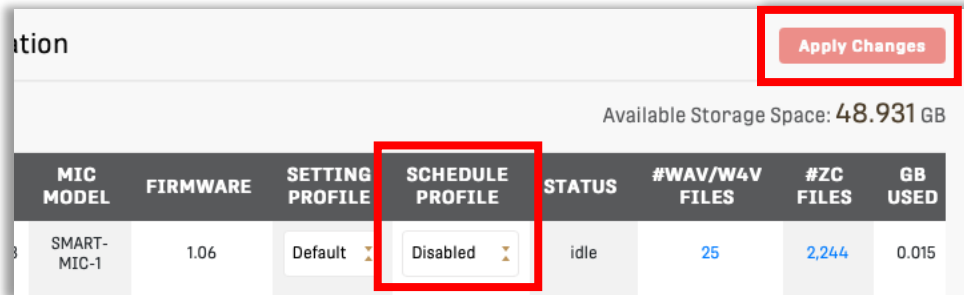

5. Choose the Record Always schedule.

6. Press the Apply Changes button.

This will cause the sensor calibration to occur. The calibration test will take ten seconds or less.

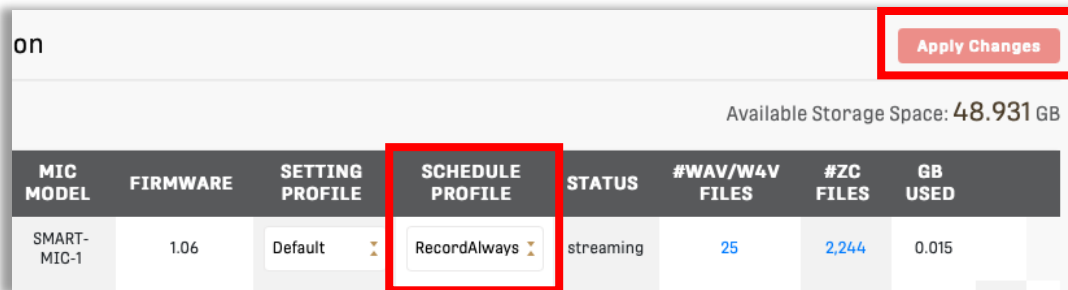

7. After pressing the Apply Changes button, wait 15 seconds, then go to the next step.

8. Set the Schedule Profile to Disabled again.

This will cause the log file to be updated with the current calibration test information.

9. Click on the Data Files tab.

- a. Check Log Text Files.
- b. Select the MIC-1 device.

- c. Select today's date for the Date range.
- d. Press the Download All To Zip button.

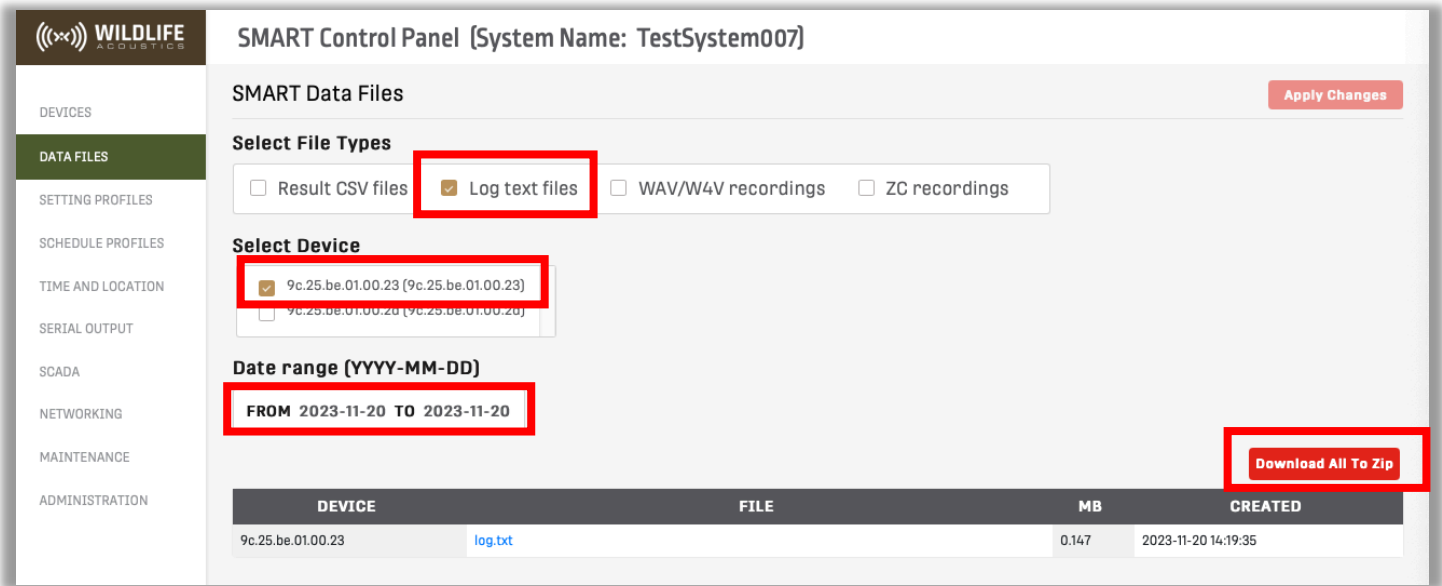

10. Go to the web browser download folder and double-click to open the data.zip file.

The data.zip file will decompress to a series of folders which ultimately contain the log.txt file.

11. Double-click to open the log.txt file.

12. Scroll to the last line in the log file.

The last four columns show the results of the calibration test.

In the following graphic, the log shows that the backup sensor is currently in use. The next two numbers show the results of the calibration test for the primary and backup sensors. The last number shows the calibration target which is currently specified in the Settings Profile.

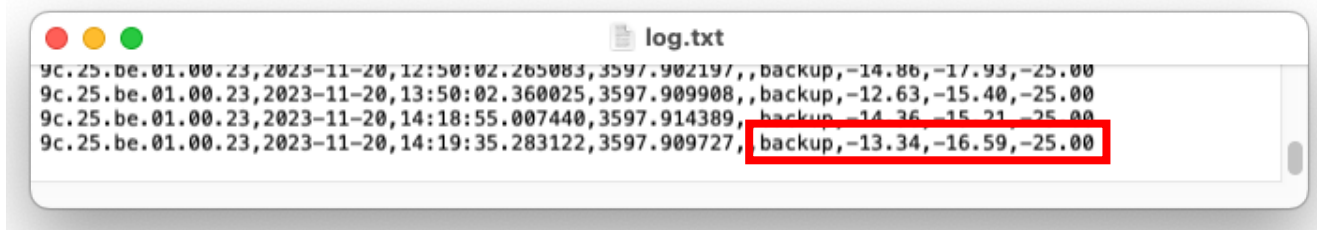

5.4 Heater

The SMART MIC-1 features an integrated heating element on its front plate. The purpose of this is to clear condensation from the Ultrasonic Sensors. Whether or not the heater function is required depends on deployment conditions.

- The Heater will increase the temperature of the front plate of the SMART MIC-1 to roughly 20°C above ambient temperature.
- A Device Profile determines if and when the heater will be on and when it will be off within the currently assigned Schedule Profile.
- Heater settings are assigned in the [Settings Profile tab](#).

5.5 Mounting Bracket

A Mounting Bracket for the SMART MIC-1 is available from Wildlife Acoustics. This section will describe how to mount the SMART MIC-1 using the Wildlife Acoustics Mounting Bracket. If a different method is used to mount the SMART MIC-1, these instructions can be used as a reference.

General Specifications

- Tested to MIL-STD 810G, Method 514.6 Vibration per Category 4, for 30 minutes on each axis
- Made from fully weatherproof stainless steel
- Can be used for surface or through-wall mounting



Connect the SMART MIC-1 to the Mounting Bracket

NOTE: Depending on deployment circumstances, it may be easier to connect the SMART MIC-1 to the bracket after the bracket has been mounted.

Required Tools and Parts (not included):

- 3/8" or M10 diameter bolts to attach the bracket to mounting surface
 - Loctite® Threadlocker Blue 242 (or equivalent) sealant
 - CAIG DeoxIT® L260DCp (or equivalent) Lithium Grease
 - Torque wrench
1. Loosen the bolts so the SMART MIC-1 can slide into the bracket. If different holes are required to achieve the desired mounting orientation, remove the bolts completely while taking note of the correct assembly sequence:

Assemble in this order:

1. bolt
2. lockwasher
3. flatwasher
4. bracket
5. spacer
6. clamp
7. flatwasher
8. lockwasher
9. nut



2. Ensure the grounding strip on the SMART MIC-1 makes contact with the bracket.

- a. Loosen or remove the clamp bolts so the SMART MIC-1 slides easily into the clamp.
- b. Apply a bead of electrical grease to the grounding strip of the SMART MIC-1.

NOTE: For surface mounting, apply the grease bead at the end of the SMART MIC-1 with the RJ45 Ethernet connection. For through-wall mounting, check the position of the SMART MIC-1 in the bracket before applying grease.

- c. Smear the grease bead for complete coverage of the grounding strip where the clamp will make contact.

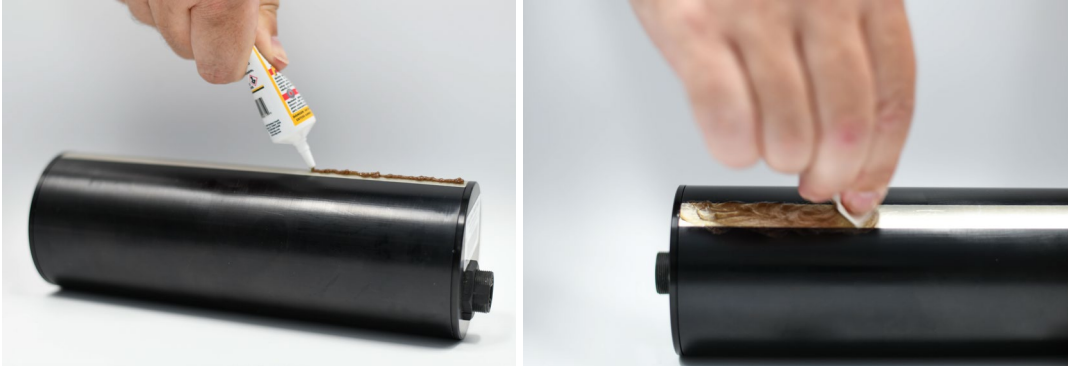

- d. Orient the SMART MIC-1 Grounding Strip opposite the open side of the clamp.
- e. Insert the SMART MIC-1 carefully so the grease is not scraped off by the bracket.

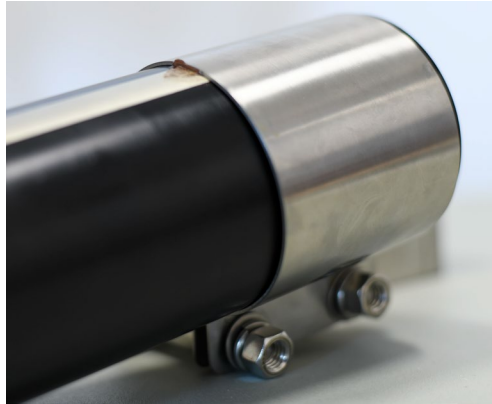

3. Tighten the Clamp Bolts to secure the SMART MIC-1.
 - a. Use LoctiteR Threadlocker Blue 242 (or equivalent) sealant on both clamp bolts as an added measure to insure that they will remain securely fastened.
 - b. Use a dry rag to wipe debris and oil from the male threads of the bolt where it will enter the nut.
 - c. Coat the male threads of the bolt with several drops of sealant.
 - d. Thread the bolt into the nut and tighten to 15 ft-lb.
 - e. Clean residual sealant with a damp rag.



Install the Mounting Bracket

The Mounting Bracket can be installed to a surface or can be configured for through-wall mounting. Use 3/8" or M10 diameter bolts (not included) to attach the bracket to the mounting surface.

NOTE: If the microphone is fitted through the a floor or wall, the front of the microphone must be flush with the external surface of the enclosure. If the front of the SMART MIC-1 is recessed or protrudes through the hole, this will adversely affect audio performance.

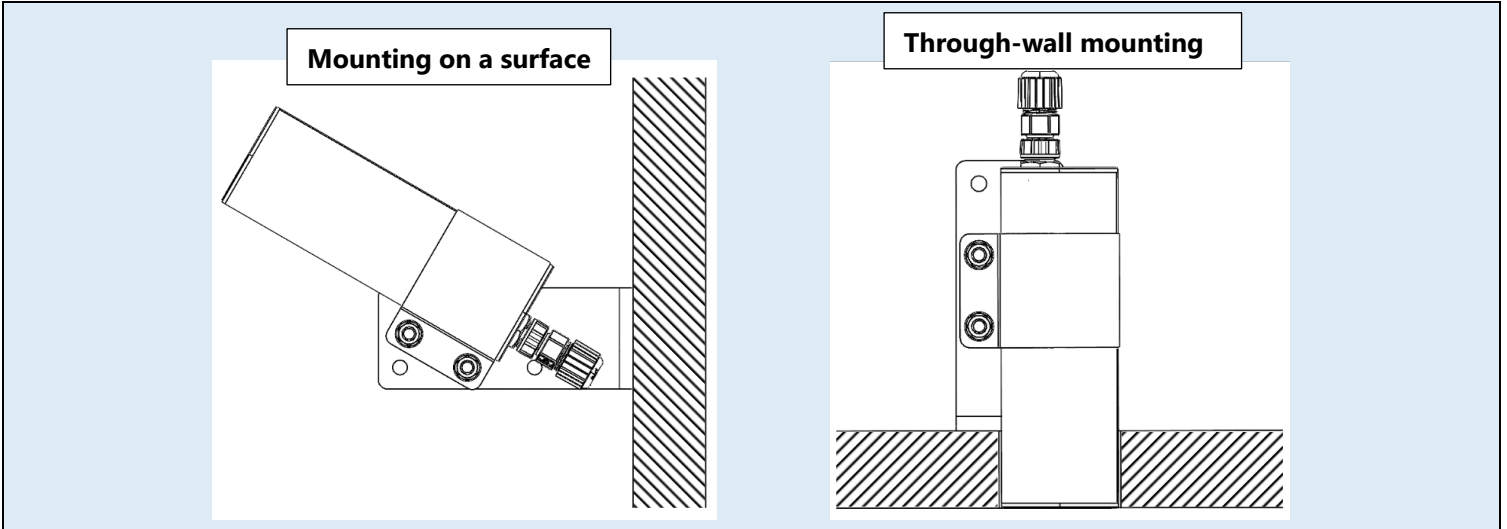

Connect to Ground

It is essential that the SMART MIC-1 has a connection to ground for the sake of electrical spike protection. The SMART MIC-1 has an external grounding strip for this purpose. The Mounting Bracket provides electrical connection to the grounding strip on the SMART MIC-1. The Mounting Bracket must subsequently be connected to ground. This is done by connecting a grounded wire to one of the mounting bolts.

Mounting Orientation

The SMART MIC-1 has directional pickup characteristics. Therefore, the sensors should be pointed in the direction of the most likely path of the bat.

The surface or through-wall position to which the Mounting Bracket is connected can be at any angle or orientation. The Mounting Bracket then provides six different positions for connection of the SMART MIC-1.

- Horizontal surface mount

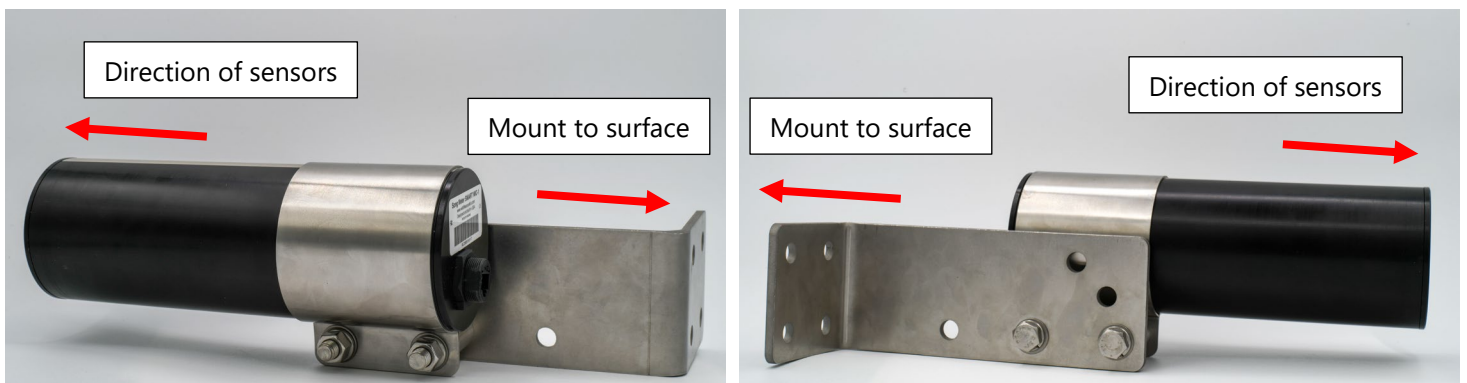

- Horizontal through-wall mount

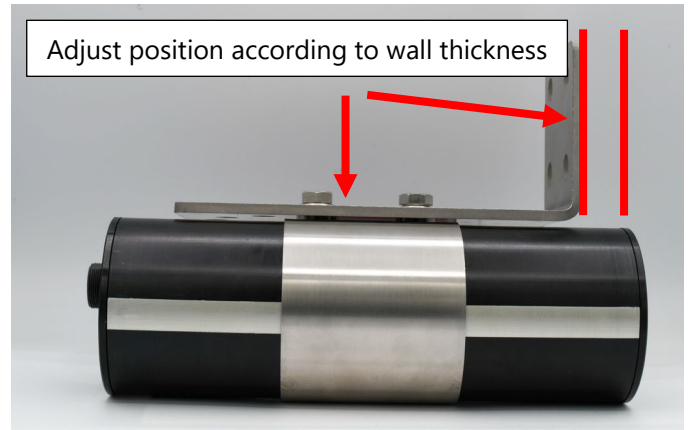
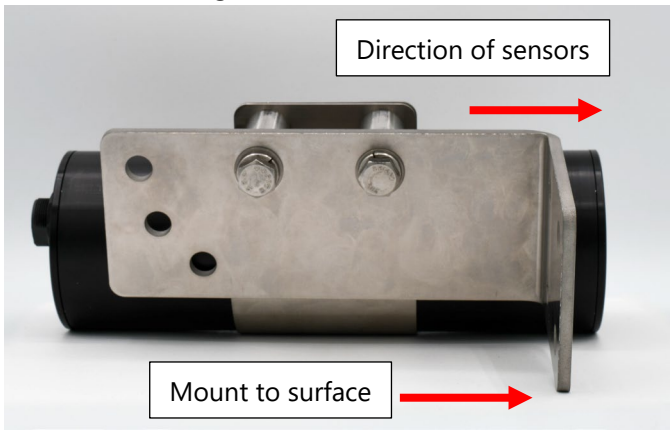

- 30° surface mount (shown oriented above horizon)



- 60° surface mount (shown oriented above horizon)



- Flipping the bracket 180° relative to the ground provides orientation 30° or 60° below the horizon.

5.6 Cable Connection Instructions

The SMART MIC-1 uses an RJ45 port for connection to the SMART Controller.

- A standard CAT5/6 cable is used for connection.

NOTE: For outside cable installation, use UV stable ethernet cable.

- The SMART MIC-1 requires Power Over Ethernet (PoE).
 - The SMART Controller provides 2 PoE ports for one or two directly connected SMART 1 MICs.
 - A PoE Ethernet switch/injector can be used to extend the connection.
 - Maximum cable length between the MIC-1 and the SMART Controller (or PoE Ethernet switch/injector) is 100 meters.
 - Fiber optic cables can be used with Ethernet adapters on each end. This can provide reduction of electrical interference over distance.
 - Maximum length with fiber optic cable is 2km.
1. Assemble and connect the [RJ45 Weatherproofing and Ferrite Kit](#) to the CAT 5/6 cable which will connect to the SMART MIC-1.
 2. Attach the CAT 5/6 ethernet cable with with the RJ45 weatherproofing and ferrite kit to the SMART MIC-1.
 3. Feed the ethernet cable from the SMART MIC-1 to the final position of the SMART Controller.
 4. Connect the [Surge Protector](#).
 5. Ground the surge protector using the wire on the surge protector.
 6. Plug the ethernet cable from the SMART MIC-1 into the surge protector.
 7. Plug the short 30cm ethernet cable provided into the second RJ45 Port on the surge protector.
 8. Plug the other end of the 30cm ethernet cable into one of the "LAN Switch with PoE" RJ45 Ports on the Controller (port 2 or 3).

RJ45 Weatherproofing and Ferrite Kit

- Each SMART MIC-1 ships with an RJ45 Weatherproofing and Ferrite Kit.
- The kit is used to prepare the cable connection to the SMART MIC-1 for weatherproofing and EMI rejection.



1. Make sure the CAT5/6 cable fits through the End Collar. For a commercial cable, it may be necessary to carefully cut the cover off from around the actual RJ45 connector.

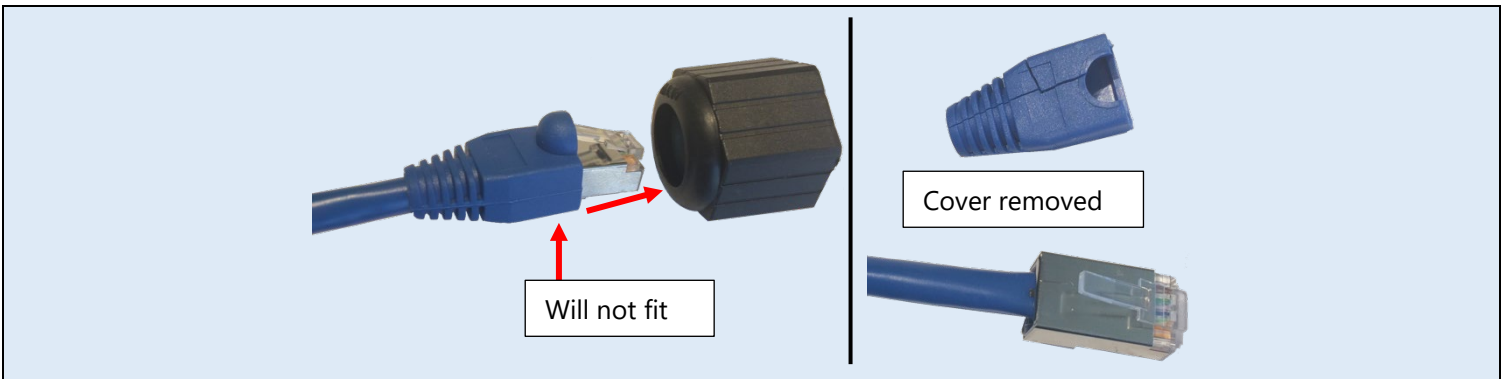

2. Thread the CAT5/6 cable through the End Collar. The Waterproof Grommet and Cable Sleeve slip over the cable through their cutouts. Make sure the pieces are in the correct order. Make sure the End Collar is oriented with its open threads towards the connector.

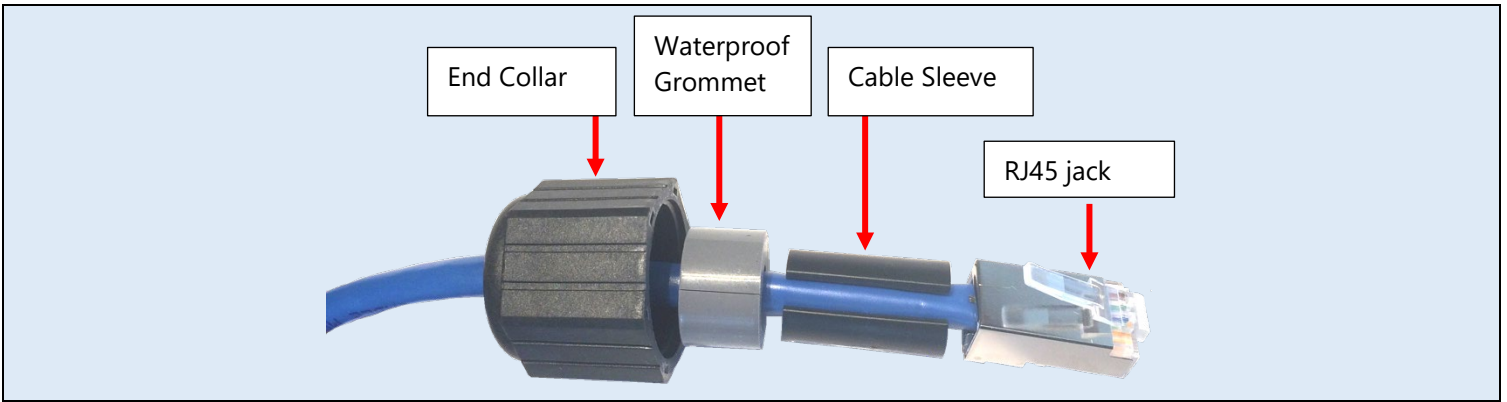

3. Thread the CAT5/6 cable with RJ45 jack through the Connector Body so the tab on the RJ45 jack fits through the slot at the end of the Connector Body.

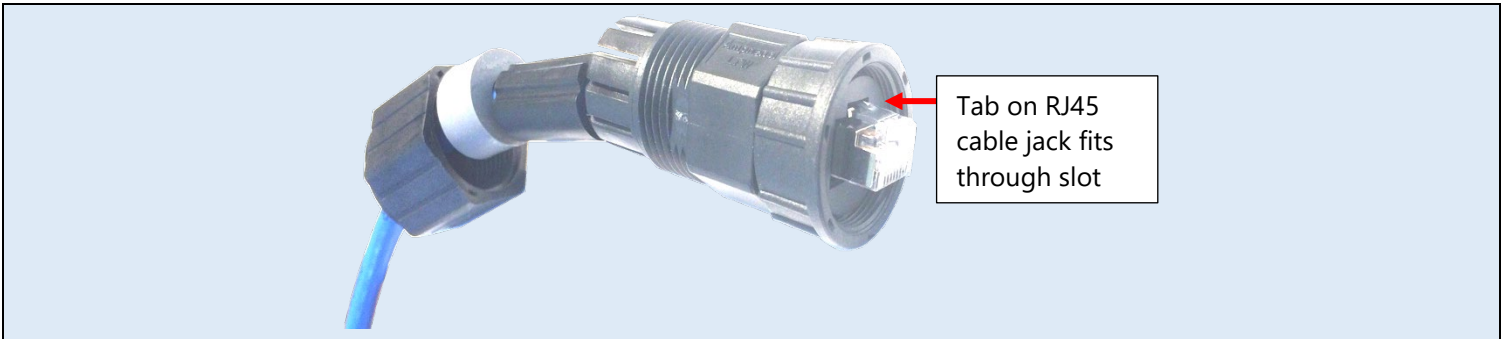

4. Push the Cable Sleeve into the Connector Body, followed by the Waterproof Grommet. The Waterproof Grommet should be flush with the end of the Connector Body.

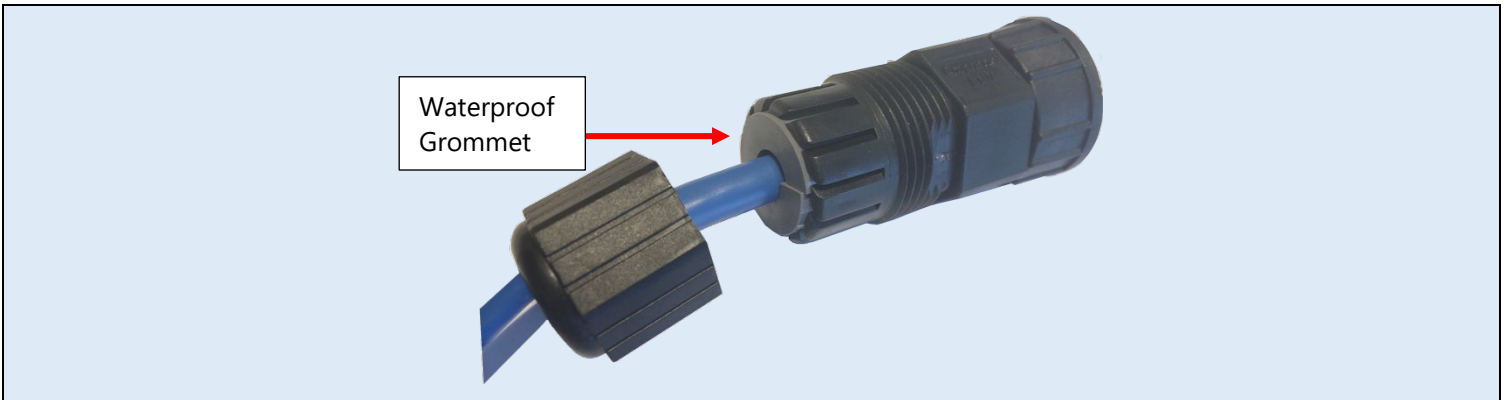

5. Push the End Collar onto the Connector Body and then turn to tighten. The threaded End Collar will screw on to the Connector Body and tighten against Waterproof Grommet to create a seal.

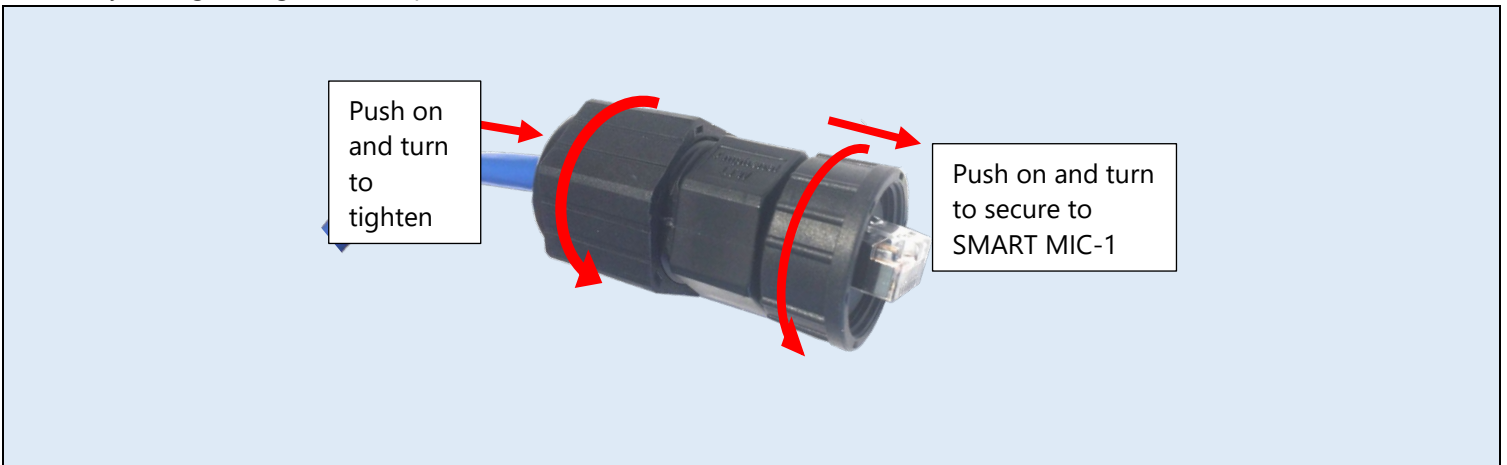

- Attach a zip-tie to the cable, as close as possible to the End Collar. This is to prevent the Ferrite from knocking or vibrating against the End Collar.

NOTE: Do not overtighten the zip-tie. The zip-tie should only be tight enough to prevent the ferrite from slipping down the cable. Overtightening the zip-tie can damage the cable.

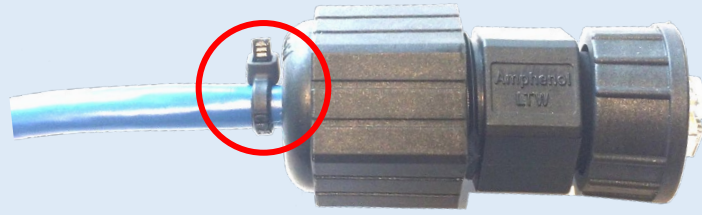

- Position the Ferrite under the cable and fold it over to close. The two tabs will snap shut.



- Attach the second zip-tie to secure the Ferrite in place.

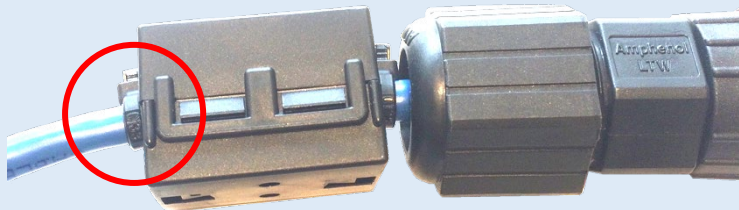

NOTE: The Ferrite must be connected to the end of the cable which connects to the SMART MIC-1, and must be as close as possible to the connector.

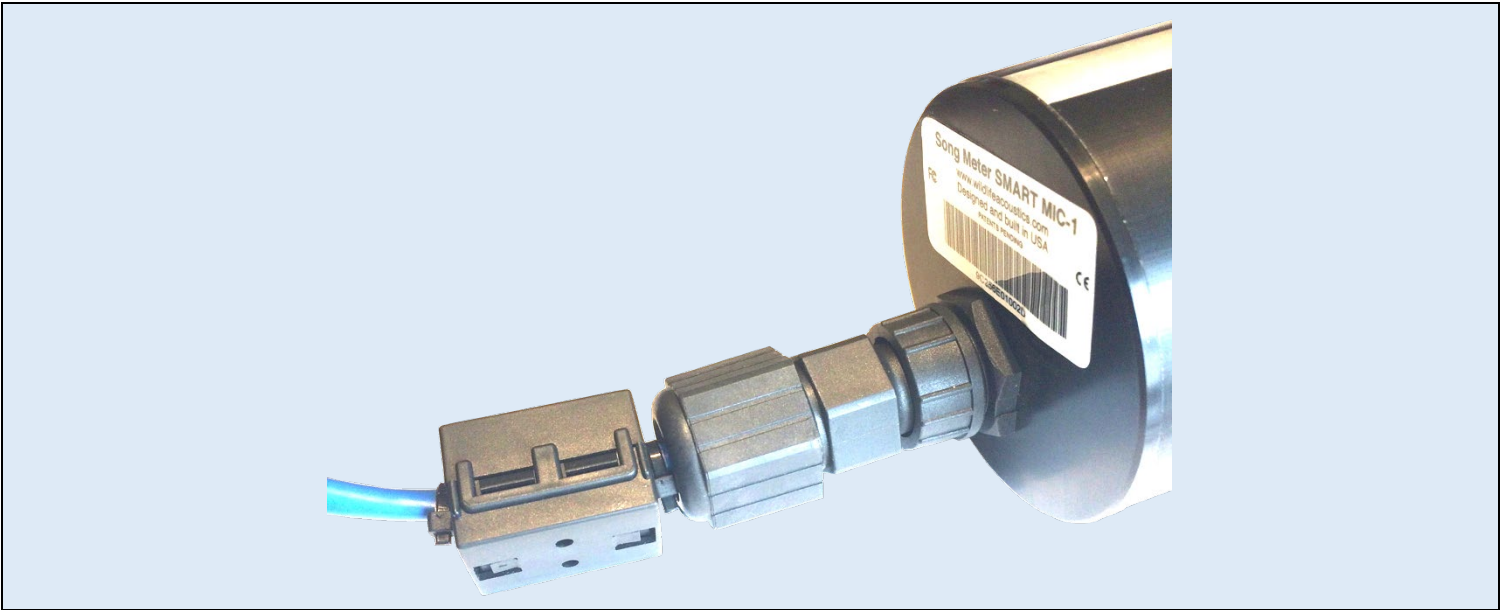

The CAT5/6 cable is now connected to the RJ45 port of the SMART MIC-1. The Integrated Screw-On Collar has been turned and tightened to provide a secure and waterproof connection. The Ferrite is tight against connector and held in place with the two zip-ties.

RJ45 Surge Protector

- Each SMART MIC-1 ships with an RJ45 Surge Protector.
- The Surge Protector is used to help protect the next device in line from electrical charges, such as nearby lightning.
- The Surge Protector must be connected to the opposite end of the CAT5/6 cable which connects the SMART MIC-1 to either the SMART Controller directly, or a PoE switch.
- The cable used to connect the Surge Protector to the SMART Controller or PoE switch should be as short as possible.
- There are two RJ45 ports on the Surge Protector. It does not make any difference which port is used to connect to the SMART MIC-1 or the SMART Controller/PoE switch.
- The Surge Protector must be connected to a common ground source.

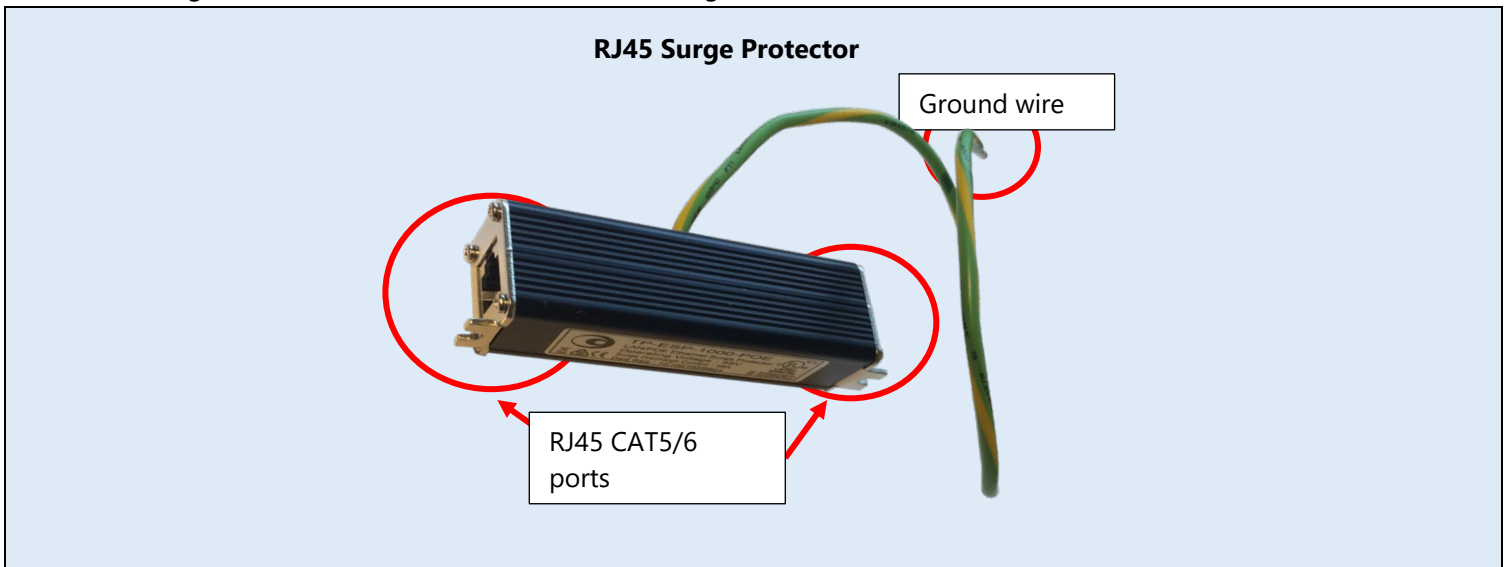

5.7 Example Configurations

The following are graphic descriptions of three possible configurations of SMART MIC-1 microphone systems and a single SMART Controller.

- An RJ45 Surge Protector is always used with the CAT5/6 cable connected to the SMART MIC-1.

- The Surge Protector must be connected at the end of the cable closest to the SMART Controller or PoE switch (Furthest away from the SMART MIC-1).
- The connection cable between the Surge Protector and SMART Controller or PoE Switch should be as short as possible.

Single SMART MIC-1 Connected Directly to SMART Controller

- Grounded metal mounting bracket
- Waterproof RJ45 connector
- Ferrite
- Up to 100 meters CAT 5/6 cable
- Grounded surge protector
- Grounded SMART Controller

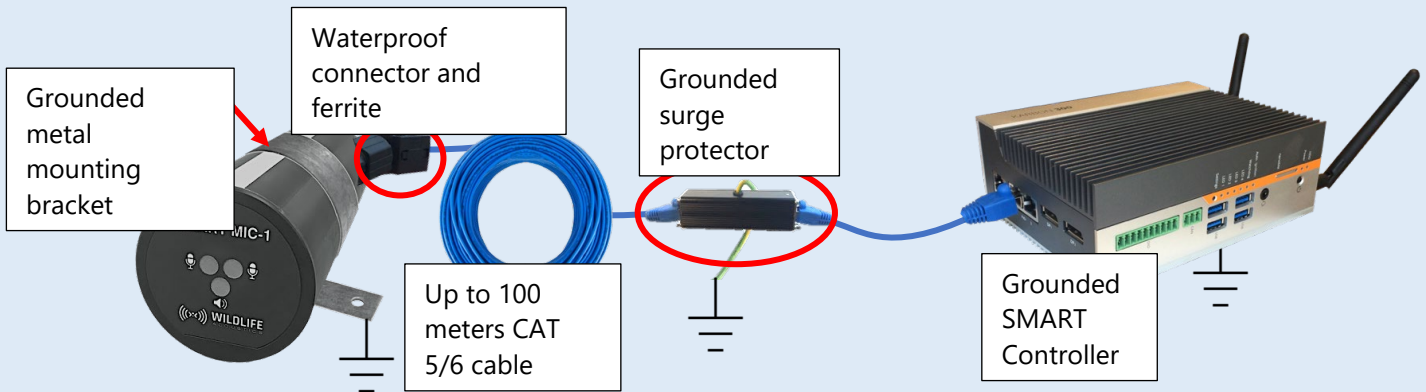

Two SMART MIC-1 Devices Connected Directly to SMART Controller

- Grounded metal mounting bracket
- Waterproof RJ45 connector
- Ferrite
- Up to 100 meters CAT 5/6 cable
- Grounded surge protector
- Grounded SMART Controller

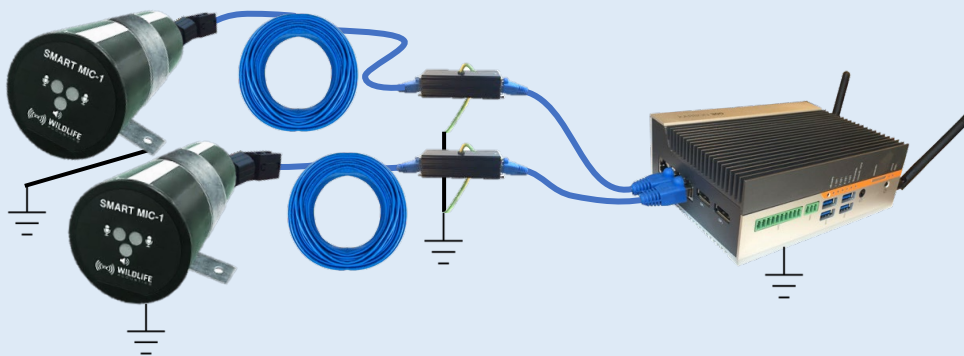

Three SMART MIC-1 Devices Connected to PoE Switch and SMART Controller

Each SMART MIC-1 connects to:

- Grounded metal mounting bracket
- Waterproof RJ45 connector
- Ferrite
- Up to 100 meters CAT 5/6 cable
- Grounded surge protector

One to three SMART MIC-1 devices can then connect to:

- PoE Switch
- PoE switch can then connect to:
 - Up to 100 meters CAT 5/6 cable
 - Grounded SMART Controller

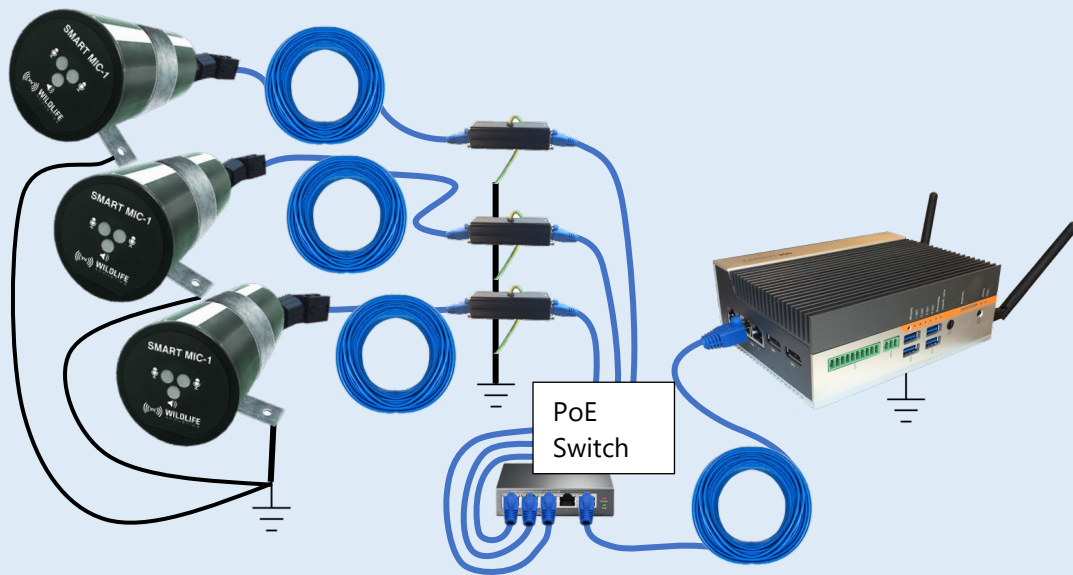

6 Connection to the SMART System

The SMART System can be accessed locally, or remotely via a network connection.

The SMART System can be accessed via a web browser or command-line interface.

Network configuration for the SMART System is flexible and customizable.

We strongly recommend you obtain assistance from an Information Technology specialist for connecting SMART to a network.

6.1 Direct Keyboard and Monitor

Direct keyboard and monitor connection provides Linux command-line access to the SMART System.

1. Connect a video monitor to the first Display port on the SMART Controller. DisplayPort adapters and connection cables are commonly available if required.
2. Connect a USB Keyboard to any USB port on the Controller. A mouse is not required.

NOTE: The base model SMART Controller includes four USB ports. Any of these ports can be used to connect a keyboard. The USB ports can also be used to connect external hard drives for backup storage. For details on using an external USB drive for backup storage, see the [Maintenance tab](#) section.

3. From the initial prompt on the screen, log on with user name and password. The default user name is "smart". The default password is "wildlife", until changed either by the web interface or the password command.
4. Further command line functions are now available.
5. The SMART user is allowed to "sudo" for super user access to the underlying Linux System.

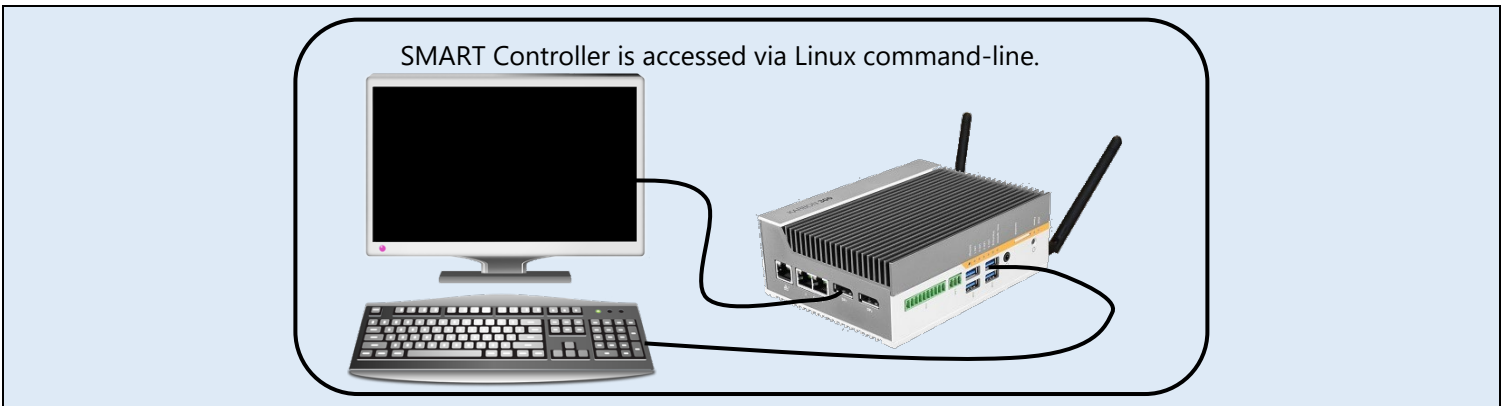

6.2 Network Configuration

The base model SMART Controller provides pre-configured network connection via built-in WIFI or RJ45 Ethernet port.

Depending on user requirements, other network connection protocols can be made available.

- The configuration of the WIFI and Ethernet connections on the SMART Controller are determined by the [netplan](#).
- The default netplan configures the SMART Controller WIFI to function as a WIFI HotSpot access point.
- The default netplan configures the Ethernet port of the SMART Controller to acquire its configuration from the network using DHCP.
- The netplan can be edited and applied to change the network configuration under the [Networking tab](#) of the web interface.

NOTE: If the netplan is applied incorrectly, the SMART System may become inaccessible via WIFI or Ethernet connection. If this happens the default netplan can be restored directly via [command-line](#).

6.3 WIFI

The SMART Controller has a built-in WIFI connection for network access. The default netplan is configured to provide a WIFI HotSpot access point for the SMART Web Interface.

- Any WIFI-enabled device which can run a web browser can access the SMART Controller directly.
- SMART WIFI can be configured to provide network server/client functions.
- WIFI connection is independent from Ethernet connection. WIFI and Ethernet connections are configured separately.

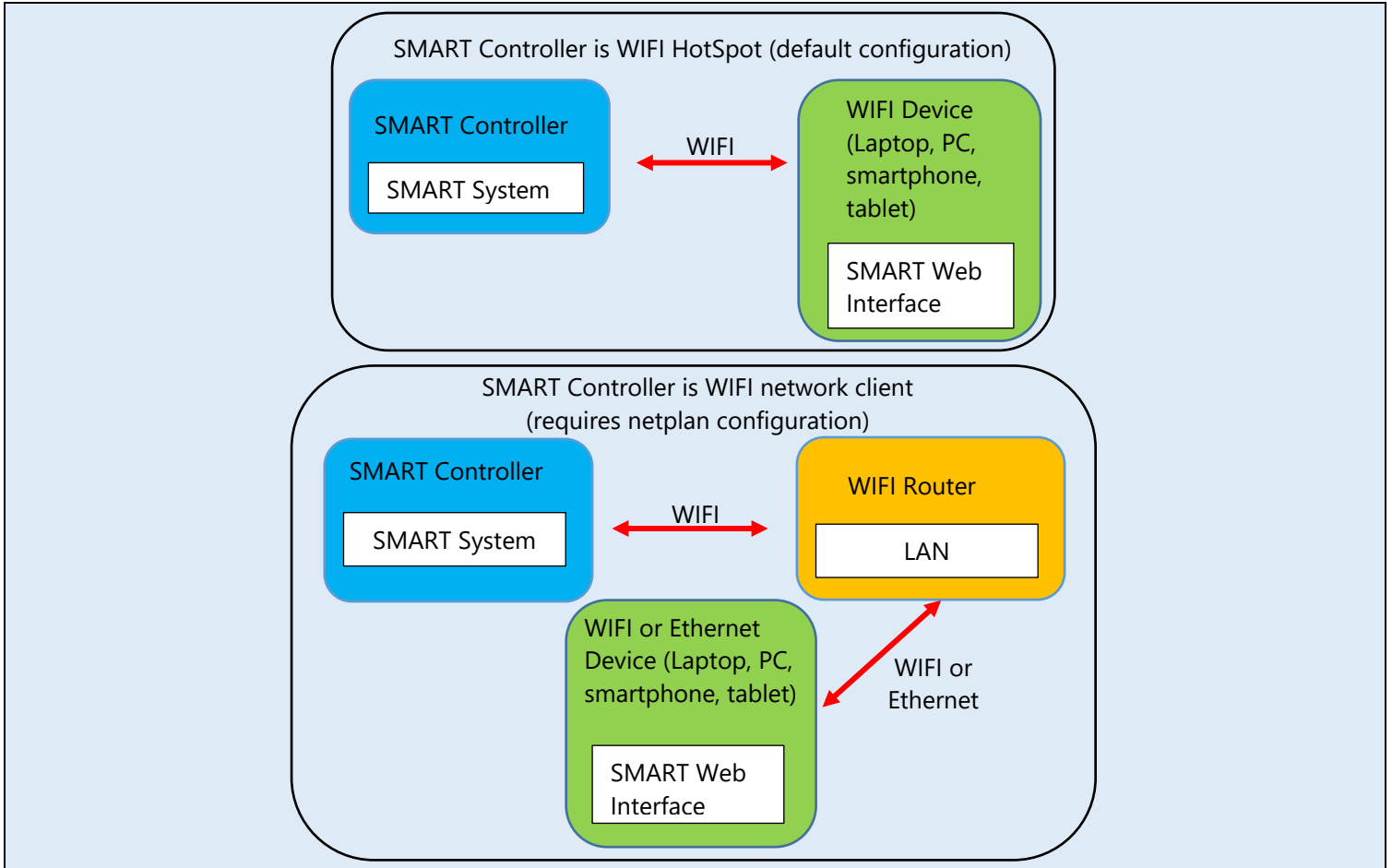

6.4 RJ45 Ethernet

The SMART Controller has three RJ45 connection ports. The ports are numbered.

- RJ45 Port number 1 is used for Ethernet connection of the SMART Controller.
- RJ45 PoE Ports numbers 2 and 3 are used for connection to one or more Devices, such as the SMART MIC-1.

The default netplan sets up the Ethernet port to acquire its configuration via DHCP.

- If the Ethernet port is connected to the Internet, the default netplan configuration will provide a path for the [SMART Internet Gateway](#).

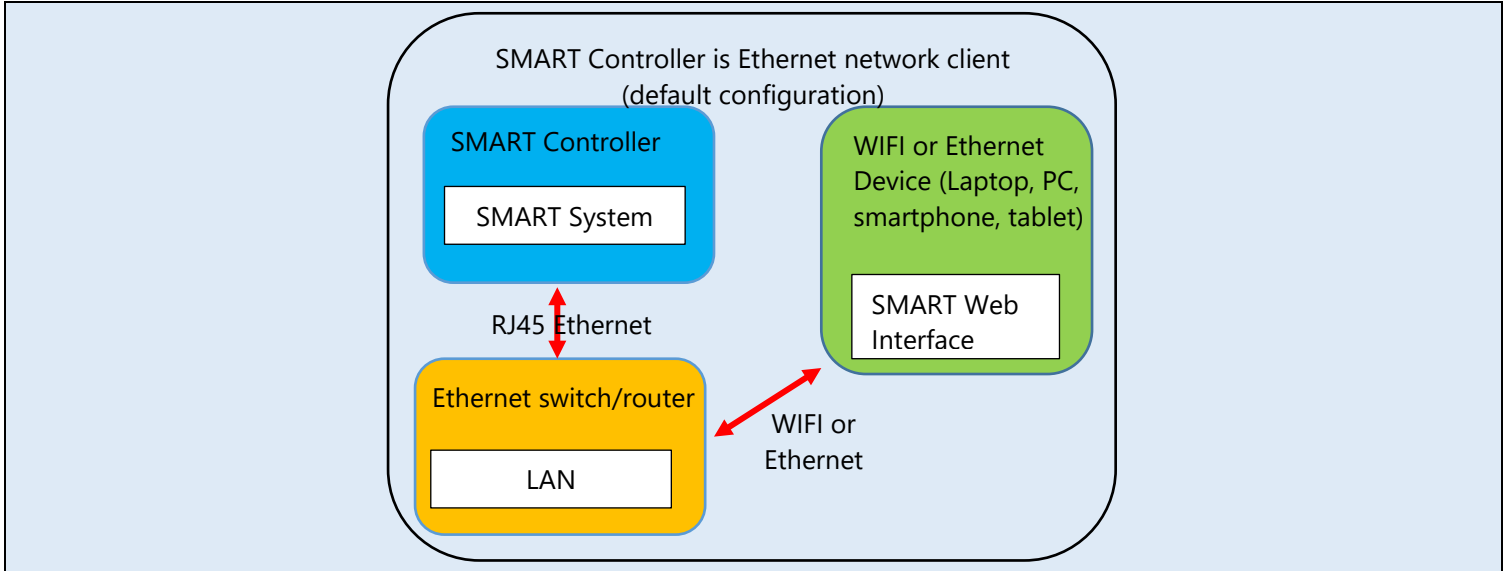

6.5 Serial

The base model SMART Controller includes two DB-9 serial ports.

The SMART System can be configured to utilize RS-232, RS-422, or RS-485 serial protocols.

The DB-9 serial ports are general purpose connections which can be used to transmit and /or receive serial data. Potential applications include:

- Weather stations
- Data Loggers
- SCADA Systems

The SMART System includes the feature of bat analysis data output through the serial port connection. This can be configured under the [Serial Output tab](#) of the Web Interface.

7 SMART Web Interface

The SMART Web Interface is the common (but not exclusive) control and monitoring point for the SMART System. The SMART Web Interface provides:

- Real time monitoring of SMART System status
- Download of recordings
- Download of log and analysis files
- Configuration and control over all parameters
- Configuration and control of network functions
- Save and recall of preset Device Settings and Device Schedules
- Administration configuration and control over authorized access to the SMART System
- Remote system update capability

The screenshot shows the SMART Control Panel interface. Key components are highlighted with callouts:

- Local Server Address:** Points to the browser address bar showing 54.82.112.64.
- SMART System Name:** Points to the header area showing (System Name: TestSystem007).
- Apply Changes button:** Points to a button in the top right corner.
- Page Selection Tabs:** Points to the left-hand navigation menu.
- Real-Time Storage Monitoring:** Points to the storage status area showing Available Storage Space: 49.043 GB.
- Microphone Status Display:** Points to a table of microphone data.
- Update notice:** Points to a button labeled 'Upgrade to 1.06'.
- System History Monitoring:** Points to the system status log area.
- Real-Time System Activity Monitoring:** Points to the system activity log area.
- Current SMART system version:** Points to a box in the bottom left corner showing Version 1.0.13-Scada-B2.

PREFIX	SERIAL NUMBER	MIC MODEL	FIRMWARE	SETTING PROFILE	SCHEDULE PROFILE	STATUS	#WAV/W4V FILES	#ZC FILES	GB USED
9c.25.be.01.00.23	9c.25.be.01.00.23	SMART-MIC-1	1.05	Test Mic	Disabled	idle			
9c.25.be.01.00.2d	9c.25.be.01.00.2d					missing	0	0	0.000

NOTE: The SMART Web Interface is not the only way to monitor and control the SMART System. The SMART System can also be monitored and controlled via command-line functions.

7.1 Connect To The SMART Web Interface

Connection to the SMART Web interface can be done through a local connection or Internet Gateway.

- For first-time setup and access to the SMART Web Interface through a local connection, see: [Quick Start Guide](#)
- For access to the SMART Web interface via the Internet Gateway, see: [Connect the SMART System to the Internet](#)

7.2 Devices Tab

- The Devices tab of the Web interface provides system status and configuration options for Devices
- The SMART MIC-1 microphone is a Device.

PREFIX	SERIAL NUMBER	MIC MODEL	FIRMWARE	SETTING PROFILE	SCHEDULE PROFILE	STATUS	#WAV/W4V FILES	#ZC FILES	US
9c.25.be.01.00.23	9c.25.be.01.00.23	SMART-MIC-1	1.05	Test Mic	Disabled	idle	0	0	0.000
	9c.25.be.01.00.2d	undefined	0.02			missing	0	0	0.000

10:27:57 up 39 days, 18:54, 0 users, load average: 0.00, 0.00, 0.00; DC Voltage: 23.44

smart-logger is running:
 smart-daemon is running:
 smart-dispatcher is running:
smart-serial is not running:
smart-scada is not running:
 smart-iot-client is running:

```

Nov 14 10:27:56 smart-iot-client[28689]: Connect request from 108.7.56.37 to 443: accepted
Nov 14 10:27:46 smart-iot-client[28689]: Connect request from 108.7.56.37 to 443: accepted
Nov 14 10:27:36 smart-iot-client[28689]: Connect request from 108.7.56.37 to 443: accepted
Nov 14 10:27:26 smart-iot-client[28689]: Connect request from 108.7.56.37 to 443: accepted
Nov 14 10:27:16 smart-iot-client[28689]: Connect request from 108.7.56.37 to 443: accepted
Nov 14 10:27:06 smart-iot-client[28689]: Connect request from 108.7.56.37 to 443: accepted
Nov 14 10:26:56 smart-iot-client[28689]: Connect request from 108.7.56.37 to 443: accepted
Nov 14 10:26:42 smart-iot-client[28689]: Connect request from 108.7.56.37 to 443: accepted
Nov 14 10:26:42 smart-iot-client[28689]: Connect request from 108.7.56.37 to 443: accepted
    
```

Add Or Delete A Device

- Connect an Ethernet cable from the Device (SMART MIC-1) to one of the two PoE RJ45 ports on the SMART Controller (either directly or via a PoE switch or injector).
- The SMART Controller will automatically detect the Device when connection is completed and PoE is provided to the Device.
- After a few seconds the new Device will be listed under the Devices tab. This indicates the Device is in communication with the SMART Controller.
- If the SMART MIC-1 Device does not appear in the list after connection, check all cables and connections. If a switch or injector is in use, make sure it is providing adequate PoE (Power Over Ethernet) to the SMART MIC-1.
- Once a Device is seen for the first time, it will remain listed on this page even if it is disconnected or loses communication with SMART System.
- Causes of lost communication could include the cable being disconnected or a loss of PoE to the Device.
- If the Device loses communication with the SMART Controller, a Delete button will appear next to the Device
- To delete a disconnected Device from the list, press the Delete button for that Device.

NOTE: If the Schedule Profile under the Devices tab is set to Disabled, the SMART MIC-1 is still detected by the SMART System and its status is "Idle".

Assign a Custom Name (Prefix) to a Device

Each Device can be assigned a custom name, known as a prefix.

- The default file name prefix for the SMART MIC-1 Device is its serial number.
- When a SMART MIC-1 creates a .wav or .zc recording file, the file name includes the Name (Prefix).

1. Click on the Name field to edit.
2. Type the custom name for the SMART MIC-1 Device
3. Press the **Apply Changes** button

Serial Number/Model/Firmware

- The serial number is unique to each Device and cannot be changed.
- There is currently a single model of microphone system available for the SMART System – the SMART MIC-1.
- The currently installed firmware version of the SMART MIC-1 Device is displayed.
- If a new firmware update is available for the SMART MIC-1, an update button will be displayed under the Device tab, when the SMART MIC-1 is Idle.

Assign a Settings Profile

- The SMART MIC-1 uses a Settings Profile to describe its detection, recording, calibration, and heating functions within the SMART System.
 - Settings Profiles are created, and saved under the [Settings Profiles tab](#).
 - Once a Settings Profile has been created and saved, it can be assigned to a SMART MIC-1 under the Devices tab.
 - Multiple Device Profiles can be created and saved and then recalled for each Device as required.
1. Choose the saved Settings Profile for the Device.
 2. Press the **Apply Changes** button

Assign a Schedule Profile

When the Device is activated, a Schedule Profile runs the currently assigned Settings Profile.

- Schedule Profiles are created, edited, and saved under the [Schedule Profiles tab](#).
 - Once a Schedule Profile has been created and saved, it can be assigned to a SMART MIC-1 Device under the Devices tab.
 - Multiple schedule profiles can be created and saved and then recalled for each SMART MIC-1 Device as required.
1. Choose the saved Schedule Profile for the Device
 2. Press the **Apply Changes** button

Device Status

- The Devices tab displays a real-time update of the status of each Device which is listed for this SMART System.
 - Idle means the Device is detected but not currently running a Schedule Profile.
 - Streaming means Device is currently running a Schedule Profile.
 - Missing means the Device is no longer in communication with the SMART System.
- The Device status, file counts, and other statistics are updated every 5 seconds.

WAV/W4V Files / # ZC Files / GB Used

The number and type of recording files currently stored on the SMART Controller, and the storage space used, is listed for each Device

Delete/Update a Device

If a Device is no longer in use (and is reported as **Missing**), then a Delete button is shown and can be used to remove the Device from the list.

- This will not delete any saved data related to the Device.
- To delete old data, configure this function under Maintenance tab.
- If a new Device firmware update is available, an "Update to version x.xx" button will be available when the Device with older firmware is in the **Idle** state.

GB Available

- This provides a real-time display of the available memory for recording files.
 - As more recording files are created and stored on the SMART Controller, this number will decrease.

SMART Controller Status

The following information is displayed and is also the output of the Unix/Linux command "uptime":

- History of time and status since last reboot
- Number of user log-ins to the SMART Unix/Linux command shell
- Load average relates to the average CPU load in the last 1, 5, and 15 minute period.
- Each number is relative to a single CPU core average.
- Maximum load average is 2.0.
- 0.0 means not active at all.

The following additional information is displayed:

- DC Voltage - This is updated every minute or so (tunable) and is the last single reading made.

The following status information is displayed in real-time:

- smart-logger
- smart-daemon
- smart-dispatcher
- smart-serial
- smart-scada
- smart-iot-client

A scrollable list is displayed to show SMART system activity during the current log-in session.

```

10:57:27 up 39 days, 19:24, 0 users, load average: 0.00, 0.00, 0.00; DC Voltage: 23.43

smart-logger is running:
smart-daemon is running:
smart-dispatcher is running:
smart-serial is not running:
smart-scada is not running:
smart-iot-client is running:

Nov 14 10:57:27 smart-iot-client[28689]: Connect request from 108.7.56.37 to 443: accepted
Nov 14 10:57:17 smart-iot-client[28689]: Connect request from 108.7.56.37 to 443: accepted
Nov 14 10:57:07 smart-iot-client[28689]: Connect request from 108.7.56.37 to 443: accepted
Nov 14 10:56:57 smart-iot-client[28689]: Connect request from 108.7.56.37 to 443: accepted
Nov 14 10:56:47 smart-iot-client[28689]: Connect request from 108.7.56.37 to 443: accepted
Nov 14 10:56:37 smart-iot-client[28689]: Connect request from 108.7.56.37 to 443: accepted
Nov 14 10:56:27 smart-iot-client[28689]: Connect request from 108.7.56.37 to 443: accepted
Nov 14 10:56:17 smart-iot-client[28689]: Connect request from 108.7.56.37 to 443: accepted
Nov 14 10:56:07 smart-iot-client[28689]: Connect request from 108.7.56.37 to 443: accepted

```

7.3 Data Files Tab

DEVICES

DATA FILES

SETTING PROFILES

SCHEDULE PROFILES

TIME AND LOCATION

SERIAL OUTPUT

SCADA

NETWORKING

MAINTENANCE

SMART Data Files Apply Changes

Select File Types

<input checked="" type="checkbox"/> Result CSV files	<input type="checkbox"/> Log text files	<input type="checkbox"/> WAV/W4V recordings	<input type="checkbox"/> ZC recordings
------------------------------------------------------	-----------------------------------------	---------------------------------------------	----------------------------------------

Select Device

9c.25.be.01.00.23 (9c.25.be.01.00.23)
 9c.25.be.01.00.2d (9c.25.be.01.00.2d)

Date range (YYYY-MM-DD)

FROM YYYY-MM-DD TO YYYY-MM-DD

- The Data Files tab provides direct file download functions for the SMART Controller.
- Files can also be automatically sent to a network destination or backed up to a local USB drive via the [Maintenance tab](#).
- Data files can be filtered by:
 - Device
 - Date range
 - Result CSV files
 - Log files
 - WAV/W4V recordings
 - ZC recordings

- Press the **Apply Changes** button to create a list of filtered files.
- Individual files can be downloaded by clicking on the file links.

Multiple filtered files can be selected and downloaded as a single .ZIP archive.

Download All To Zip			
DEVICE	FILE	MB	CREATED
	smart-dispatcher.log	0.004	2021-03-26 15:21:56
	2021-03-27_00-00-01-smart-cron-log.txt	0.004	2021-03-27 00:00:01
	2021-06-26_00-00-01-smart-cron-log.txt	0.381	2021-06-26 00:00:01
	2021-06-26_00-00-01-smart-daily-log.txt	0.066	2021-06-26 00:00:01
	2021-09-28_00-00-01-smart-cron-log.txt	0.250	2021-09-28 00:00:01
	2021-09-28_00-00-01-smart-daily-log.txt	0.045	2021-09-28 00:00:01
	2021-12-27_00-00-01-smart-cron-log.txt	0.025	2021-12-27 00:00:01
	2021-12-27_00-00-01-smart-daily-log.txt	0.053	2021-12-27 00:00:01
	2022-03-28_00-00-01-smart-cron-log.txt	0.176	2022-03-28 00:00:01
	2022-03-28_00-00-01-smart-daily-log.txt	0.053	2022-03-28 00:00:01

Select File Types

- Select the file type to be included in the list:
 - Result CSV files
 - Log Text Files

NOTE: If Alarms are in use under the SCADA tab, a triggered Alarm will create a smart-scada-log.txt file that logs alarm events as they are made available to SCADA over modbus.

- WAV/W4V recordings
- ZC recordings

Select Devices

- All Devices which have ever been connected to this SMART Controller are listed here.
 - This includes Devices which may have been deleted from the Devices tab.
 - Select one or more Devices to include data from those Devices.

NOTE: If no Device is selected and Log text files is checked, system logs are listed and can be downloaded.

Date Range (YYYY-MM-DD)

- Select the Date Range from which to include files.
 - From:
 - To:
 - If either field is left blank, all files before or after the date which is specified will be listed

7.4 Settings Profiles Tab

Customized configurations for Devices can be created and saved. A customized Device configuration is a Settings Profile.

- The Settings Profiles tab provides functions for creating and saving customized Device configurations (Settings Profiles).
- Individual Settings Profiles can be recalled and are assigned to a Device under the [Devices tab](#).

Model menu

- This menu is used to select which Device model is described by the Settings Profile.
- Currently the SMART MIC-1 is the only Device model available for the SMART System

Profile menu

- This menu provides a list of saved Settings Profiles.
- The Settings Profiles listed in this menu are available for selection under the Devices tab.

Apply Changes

Press the Apply Changes button to save or update the currently selected Device Profile.

Delete Profile

Press the Delete Profile button to delete the currently selected Device Profile.

Duplicate Profile

Press the Duplicate Profile button to duplicate the currently selected Device Profile.

Profile Name

Each Settings Profile must be named in order to be saved.

Sample Rate

The choice of sample rate determines the number of samples per second used to store any sounds detected during a recording period. Higher sample rates provide the ability to record higher frequencies. Choose a sample rate that is at least double the highest frequency to be recorded. Note, the higher the sample rate, the larger the files will be in storage size.

Values: 256 kHz, 384 kHz, 500 kHz

Default: 256 kHz

High-Pass Filter

This sets the analog high-pass filter. A high-pass filter allows signals only higher than the specified frequency to be recorded. The high-pass filter is a two-pole filter, which attenuates sounds at 12dB per octave. When the filter is on, an 8 kHz sound would be attenuated by 12dB as it is one octave lower than the 16 kHz frequency of the filter. Every 6dB represents a halving of sound level, so the 8 kHz sound would appear in the recording at one-fourth of its original amplitude.

If you expect bats vocalizing below 8 or 16 kHz, set the high-pass filter to 8 kHz or off, and an appropriate Min Trig Freq (see below). The filter in the microphone reduces acoustic sounds below the threshold frequency but you will still get more noise files with setting this filter to off. It is a compromise. If you do not expect bats below 8 or 16 kHz, enable the high-pass filter in order to reduce acoustic sounds that might cause non-bat recordings to occur. Be sure to also set an appropriate Min Trig Freq (see below).

Values: 8 kHz (Off), 16 kHz (On)

Default: 16 kHz

Gain

The gain setting is used to boost the input level of the audio signal from the microphone. 12 dB is recommended for maximum detection range. 0 dB will reduce clipping distortion if the bats are closer to the microphone.

Values: 0 dB, 12 dB

Default: 0 dB

Duration (seconds, if specified)

This specifies the maximum length (time duration) of recordings to comply with file size restrictions of analysis software or to fulfill a specific recording protocol or definition of a bat pass.

- The **Duration** setting takes effect regardless of whether **Bat Analysis/Triggering** is enabled or not.
- If no Duration is specified, recording length is determined by trigger presence or 2 GB maximum file size.
- If a recording reaches maximum Duration but the trigger is still present, the recording file is ended and a new consecutive recording file is created.

Values: Not Specified, 1 - (no upper limit, but determined by trigger or 2GB max file size)

Default: Not Specified

Heater On Period (seconds, if specified)

This specifies how long the Heater will be activated within the Schedule Profile Schedule Block.

If no Heater On Period is specified, the Heater will not be activated by this Device Profile.

Values: Not Specified, 1 – (no upper limit but determined by schedule block duration)

Default: Off

Heater Off Period (seconds, if specified)

This specifies how long the Heater will be deactivated within each Schedule Profile Schedule Block.

If no Heater On Period is specified, the Heater is always off.

If no Heater Off Period is specified, but there is a Heater On Period specified, the Heater will be activated once at the beginning of each Schedule Profile Schedule Block. Activation duration is determined by the Heater On Period time.

Values: Not Specified, – (no upper limit but determined by schedule block duration)

Default: Off

Heater On Period (s, If Specified) <input type="text"/>
Heater Off Period (s, If Specified) <input type="text"/>

Calibration Period (seconds, if specified)

This specifies how long the Calibration will be activated within the Schedule Profile Schedule Block. If no Calibration Period is specified, the Calibration will not be activated by this Device Profile.

Values: Not Specified, 1 – (no upper limit but determined by schedule block duration)

Default: 3600 seconds

Calibration Frequency (Hz)

This specifies the frequency of the test tone to be generated by the Ultrasonic Speaker.

Changing the Calibration Frequency allows the Calibration to test the sensitivity of the Ultrasonic Sensors at different frequencies.

Values: 8000 Hz – Nyquist (half the current sample rate)

Default: 40,000 Hz

Calibration Amplitude (ratio full scale)

This specifies the amplitude of the calibration signal relative to full scale.

Changing the Calibration Amplitude allows the Calibration to test the Ultrasonic Sensors at different relative amplitudes. Raising this value will lower the amplitude of the calibration signal.

Values: Not Specified

Default: 1

Calibration Target (dB full scale)

This is the target sensitivity of the Ultrasonic Sensor when being tested by the Calibration.

- When the test tone is generated, the sensitivity of each Ultrasonic Sensor is measured by the SMART System
- The sensitivity of each Ultrasonic Sensor is compared to the Calibration Target.
- The SMART MIC-1 will then switch to use the Ultrasonic Sensor which measures closest to the Calibration Target.
- Typical sensitivity of the Ultrasonic Sensor is approximately -20 dB FS at 40 kHz

Values: Not Specified

Default: -25 dB

Calibration Period (s, If Specified)	3600
Calibration Frequency (Hz)	40000
Calibration Amplitude (Ratio Full Scale)	2
Calibration Target (DB Full Scale)	-25

<input checked="" type="checkbox"/> Bat Analysis / Triggering
<input checked="" type="checkbox"/> Disable when heater is on
<input checked="" type="checkbox"/> Output WAV
WAV Compression None ▾
<input checked="" type="checkbox"/> Output ZC
<input type="checkbox"/> Disable Enhanced ZC

Bat Analysis/Triggering

This checkbox determines whether the analysis and triggering functions are enabled.

- If Bat Analysis/Triggering is unchecked, the SMART System will not generate analysis statistics.
- If Bat Analysis/Triggering is unchecked, streaming audio will be recorded continuously, with the maximum file length limited by the specified [Duration](#), or 2GB file size.

Values: On/Off

Default: On (Checked)

Disable When Heater Is On

This function is available only when Bat Analysis/Triggering is checked.

This checkbox disables triggered recording and analysis when the heater element is enabled. This will prevent false triggers in situations where a noisy power supply introduces noise through the heater.

Values: On/Off

Default: On (Checked)

Output WAV

This checkbox determines whether .wav files will be recorded when the SMART MIC-1 streams audio to the SMART Controller.

- Creation of .wav files is subject to trigger parameters
- Creation of .wav files is further based on the current Schedule Profile.

Values: On/Off

Default: On (Checked)

WAV Compression

This function is available only when Output WAV is checked.

WAV file compression can be selected to record in a proprietary compressed W4V format. The benefit is reduced file size. The W4V format is a WAV file compression developed specifically for minimizing loss of useful information in bioacoustics audio recordings. There are three available compression levels:

- W4V-8: 50% (allows recording twice as long as compared to uncompressed WAV)
- W4V-6: 62.5% (allows recording almost three times as long as compared to uncompressed WAV)
- W4V-4: 75% (allows recording four times as long as compared to uncompressed WAV)

The compression algorithm does increase the noise floor of the recording but for most bioacoustics uses, the difference between an uncompressed WAV and W4V-8 and W4V-6 will be undetectable since the noise floor in the recorded environment will be higher than the increased recording noise floor. W4V-4 will likely cause a slight increase in broadband noise in the background of the recording. It is best to experiment with your particular environment to make sure the increased noise is either undetectable or tolerable.

Wildlife Acoustics' Kaleidoscope Pro software can natively open the W4V compression formats. Kaleidoscope Lite can be downloaded for free from the Wildlife Acoustics website, and can be used to convert the files to standard WAV format for use in other software packages. Additionally, the W4V algorithms are open-source under GPLv3 license. Please contact Wildlife Acoustics if you are interested in a commercial license.

Values: None, W4V-8, W4V-6, or W4V-4

Default: None

Output ZC

This checkbox determines whether .zc files (Zero Crossing) will be recorded when the SMART MIC-1 streams audio to the SMART Controller.

- Recording of .zc files is subject to trigger parameters
- Recording of .zc files is further based on the current Schedule Profile.

Values: On/Off

Default: On (Checked)

The following parameters are used by the embedded Kaleidoscope Pro software for detection and analysis of bats. These functions are enabled or disabled via the Bat Analysis/Triggering checkbox.

Disable Enhanced ZC

This function is available only when Output ZC is checked.

Enhanced ZC is a collection of advanced signal processing algorithms applied to enhance bat calls.

- Enhanced ZC removes noise and competing signals prior to the zero crossing process.
- Enhanced ZC provides the full SNR (Signal to Noise Ratio) available from the full spectrum signal. This is approximately 20dB greater than what is made from a native zero-crossing recorder.
- If Disable Enhanced ZC is checked, the time domain signal is zero-cross analyzed with only a band-pass filter applied.

Values: Enabled/Disabled

Default: Enabled (Unchecked)

Kaleidoscope Pro technology is built into the SMART System. This provides real-time analysis functions.

- The analysis detects bat echolocation calls.
 - This begins a trigger.
 - The trigger end-point is specified.
 - If the conditions in the Settings Profile are satisfied, the event is defined as a bat pass.
 - Once the bat pass is complete the analysis results in call parameter extraction.
- Species auto-ID is available and can be enabled or disabled but is not available in the Serial Output.
- [Analysis statistics are included in results.csv files and Serial Output.](#)

Pre-Trigger (s)
0
Post-Trigger (s)
0

Pre-trigger (s)

Pre-trigger specifies the amount of extra time in seconds to include in the output recording prior to the first detected signal.

Values: Not Specified

Default: 0

Post-trigger (s)

The WAV recording continues for this amount of time after the last signal that satisfies the trigger. (This does not apply to .zc files).

(The recording is also truncated when it reaches the maximum recording duration set by **Max Length**.) Set the Post-trigger setting long enough to avoid a recording that ends after one echolocation call.

For example, if bat echolocation calls occur every 0.5 seconds and trigger window is 0.1 seconds, there could be a new trigger with every single echolocation call. Three (3.0) seconds is a good default value.

NOTE: Some standards describe a specific recording trigger window as a *bat pass*.

Values: 0 to 15 seconds in 1-second increments

Default: 0 seconds

Minimum Frequency (Hz)
8000
Maximum Frequency (Hz)
120000

Minimum frequency (Hz)

Use this command to set the lower bound for the frequencies of interest to the triggering mechanism and noise scrubber. Echolocation calls or other signals occurring below this frequency do not cause a trigger and are considered noise to the scrubber. A setting of 16 kHz works well for most bat applications. It may be necessary to reduce this setting for recording lower-frequency species.

Values: 2 to 99 kHz in 1-kHz increments

Default: 8000

Maximum frequency (Hz)

Maximum Frequency specifies the maximum frequency of the expected signal in Hz. It may be necessary to increase this setting for recording high-frequency species.

- Signals above the Maximum frequency will not trigger a recording.

Values: Not Specified

Default: 120000

Minimum Pulse Duration (s)
0.002
Maximum Pulse Duration (s)
0.5
Maximum Inter-Pulse Gap (s)
0.5

Minimum pulse duration (s)

Sets the minimum duration of a signal in the specified frequency range that qualifies as a valid signal for the scrubber. The scrubber automatically rejects recordings if it detects no suitable bat echolocation call. The scrubber looks for at least two narrow-band signals of at least this minimum duration, shorter than the maximum duration, and within the specified frequency range. If two such signals exist, the file is saved; otherwise, the file is not saved.

Values: none, 0.1 to 99.9 milliseconds in 0.1-millisecond increments

Default: 0.002

Maximum pulse duration (s)

Sets the maximum duration of a signal in the specified frequency range that qualifies as a valid signal for the scrubber.

- A value of *none* is recommended for recording bats.

Values: none, 1 to 500.0 milliseconds in 1-millisecond increments

Default: 0.5

Maximum inter-pulse gap (s)

This specifies the maximum inter-pulse gap in seconds.

- If there is a gap between detected pulses which exceeds the Maximum inter-pulse gap time, this is considered to be the end of the trigger.

Values: Not Specified

Default: 0.5

Maximum Sequence Duration (s)
15
Minimum Number Of Pulses
2

Maximum sequence duration (s)

If the trigger signal continues past the Maximum sequence duration, a new sequence is started.

- The Maximum sequence duration defines the maximum length of all recordings.
- If the trigger signal continues past the Maximum sequence duration, a new recording file will be created.

Values: Not Specified

Default: 15

Minimum number of pulses

Specify the minimum number of pulses required to consider a signal a bat.

- If the minimum number of pulses is not met in a triggered recording, the recording will be marked as NOISE.

- If the Minimum number of pulses is set to zero, the SMART System will not consider any triggered recording to be noise.

Values: Not Specified

Default: 2

CF Filter Max Frequency (Hz)

A filter may be applied to ignore signals within a specified frequency range. This can be useful for eliminating non-bat sound from being detected as bats.

- This setting specifies the maximum cutoff frequency which is used for filtering
- This setting is used in combination with CF Filter Max Bandwidth

Values: Not Specified

Default: 0

CF Filter Max Bandwidth (Hz)

- This setting specifies the bandwidth of the filter, starting below the maximum cutoff frequency

Values: Not Specified

Default: 0

Classifier

A Classifier is used to narrow the species choice available to the Auto-ID process.

- Select the appropriate classifier and region for the location of the SMART MIC-1.
- When a region has been selected, species are pre-selected according to Bat Conservation International recommendations
- It is then possible to add or delete individual species from the currently selected list.
- If no classifier is selected, the auto-ID analysis will not be run.

Classifier Threshold

A threshold can be specified to adjust the sensitivity of the classifier. The Classifier Threshold changes the statistical weighting and confidence for species identification. This influences the results of Auto-ID results.

- -1 More Sensitive (Liberal)
 - This setting will produce more identifications
 - Some identifications may be less accurate
- 0 Balanced (Neutral)
- +1 More Accurate (Conservative)
 - This setting will produce less identifications
 - Overall identifications and will be more accurate

The [Auto ID Classifier Performance](#) document provides statistical accuracy estimation for each of the three balance settings

Values:

- -1 More Sensitive (Liberal)
- 0 Balanced (Neutral)
- +1 More Accurate (Conservative)

Default: 0 Balanced (Neutral)

7.5 Schedule Profiles Tab

The screenshot displays the SMART Control Panel for 'TestSystem007'. The 'Device Schedule Profiles' section is active, showing a dropdown menu set to 'RecordAtNight'. To the right of this dropdown are 'Delete Profile' and 'Duplicate' buttons. Below, the 'Profile Name' is 'RecordAtNight'. The 'Start' time is set to 'Sunset', 'Duty' is 'Always', and 'End' is 'Sunrise'. Each time field has a '+' sign and '00' for minutes. An 'Apply Changes' button is in the top right corner. At the bottom, there is a '+ Add Schedule Block' button.

- A Schedule Profile is used to determine when a Device profile is active.
- Schedule Profiles are assigned to Devices under the [Devices tab](#).
- Schedule Profiles can be created, named, and saved.
- A Schedule Profile runs once each day.
- A Schedule Profile consists of one or more Schedule Blocks.
 - Multiple Schedule Blocks provide for complex daily activity programming.
 - Each Schedule Block determines when the Device Profile is active within a 24 hour period.
 - Up to 10 Schedule Blocks can be assigned to a single Schedule Profile.

Select Schedule Profile

- The Schedule Profiles menu displays all currently saved Schedule Profiles
- Existing Schedule Profiles can be selected for further editing and updating.
- Press **Duplicate** to add the currently displayed schedule as a new Schedule Profile to the SMART System.

NOTE: The Schedule Profile must have a unique Profile Name in order to be saved.

Apply Changes/Delete Profile

- When a new Schedule Profile is created, this will save the Schedule Profile into the memory of the SMART Controller.
- If an existing Schedule Profile is selected and has been edited, this will save the updated changes to the existing Schedule Profile.
- If a saved Schedule Profile is selected, a Delete button is available for that Schedule Profile.
- When a saved Schedule Profile is deleted from the SMART System, it cannot be retrieved.
- A Schedule Profile includes at least one Schedule Block.

- A Schedule Block determines when the assigned Device Profile will be active for the Device.
- All functions defined by the Device Profile are started each time a Schedule Block is activated.
- If a Duty Cycle is enabled, the Device Profile is started each time the cycle is started.
- When triggered recording is enabled, the SMART System is ready to record when the Schedule Block activates the Device.

Profile Name

- Each saved Schedule Profile must have a unique Profile Name.
- If a new Schedule Profile is not named or has the same name as an existing Schedule Profile, it cannot be saved.
- Schedule Profiles are assigned by name to Devices under the Devices tab.

Start

- This specifies when the Schedule Block will commence activity.
- Start can be specified as an absolute time of day, or can be based on sunrise or sunset times.
- When Time is selected, the next two fields specify the hour and minute of the Start time.
 - Hour 00 is midnight.
- When Sunrise or Sunset is selected, another menu appears which provides the choice of + or -.
 - Sunset and sunrise times are calculated based on date and current programmed location of the SMART System.
 - If Hours and Minutes are both left at 00, the Start time will be exactly at sunrise or sunset each day.
 - If a value is entered into the Hours and/or Minutes fields, the Schedule Block will commence at Sunrise or Sunset, plus or minus the specified Hours and/or Minutes

Duty

- **Always** specifies the Schedule Block will run continuously within its Start and End times.
- **Cycle** specifies that the Device Profile activity will be started and stopped repeatedly within the Start and End times.
 - When Cycle is selected, four new menus appear.
 - ON specifies the duration, in hours and minutes, of when the Device Profile is active within the Duty Cycle.
 - OFF specifies the duration, in hours and minutes, of when the Device Profile is inactive within the Duty Cycle.

End

- This specifies when the Schedule Block will cease activity.
- End can be specified as an absolute time of day, or can be based on sunrise or sunset times.
- When Time is selected, the next two fields specify the hour and minute of the Start time.
 - Hour 00 is midnight.
- When Sunrise or Sunset is selected, another menu appears which provides the choice of + or -.
 - Sunset and sunrise times are calculated based on date and current programmed location of the SMART System.
 - If Hours and Minutes are both left at 00, the End time will be exactly at sunrise or sunset each day.
 - If a value is entered into the Hours and/or Minutes fields, the Schedule Block will cease at Sunrise or Sunset, plus or minus the specified Hours and/or Minutes
- Multiple Schedule Blocks can be created to run within a single Schedule Profile.
- This provides for building complex daily schedules.
- There will always be at least one Schedule Block within a Schedule Profile.
- Additional Schedule Blocks can be created by pressing the Add Schedule Block button at the bottom of the Schedule Profile.
- Additional Schedule Blocks can be deleted.
- A maximum of ten Schedule Blocks can be created in a single Schedule Profile.

The following examples are designed to illustrate each of the functions of one or more Schedule Blocks:

Record Always

- The **Start** and **End** times are both set to midnight
- The **Duty Cycle** is set to **Always**.
- This causes the Schedule Block to be active continuously per each 24 hour period.

Profile Name

Start :

Duty

End :

Record At Night

- Start is set to Sunset
- End is set to Sunrise
- Sunset and Sunrise times are automatically calculated based on date and location
- This Schedule Block will record from Sunset to Sunrise per each 24 hour period.

Profile Name

Start + :

Duty

End + :

Dusk And Dawn

- This Profile Schedule uses two Schedule Blocks.
- The first Schedule Block is set to run continuously from one hour before sunset to two hours after sunset.
- The second Schedule Block is set to run continuously from two hours before sunrise to one hour after sunrise.

Profile Name

Start - :

Duty

End + :

Delete Block

Start - :

Duty

End + :

Delete Block

7.6 Time and Location Tab

WILDLIFE ACOUSTICS

SMART Control Panel (System Name: TestSystem007)

Time, Date and Location Settings Mon 2022-04-18 10:11:27 US/Eastern (-04:00)

The automatic time synchronization service is running. In order to manually set the time, you will have to first disable the service.

Disable Automatic Time Synchronization Service

Year 2022 **Month** 04 **Day** 18

Change Date

Hour 10 **Minute** 11 **Second** 04

Change Time

Timezone Africa/Abidjan

Change Timezone

Location

Latitude (if specified, positive is North, Negative is South)

Longitude (if specified, positive is East, Negative is West)

Change Location

Version 1.0.5
© 2022 Wildlife Acoustics, Inc.

- The Time and Location tab is used to set the time and time zone on the SMART System.
- Latitude and longitude location can be specified, which will then be used for calculating sunrise and sunset times and for recording metadata.
- By default, the “automatic time synchronization service” is running to adjust the SMART System clock with the network time.
 - If the SMART System will be connected to a public IP network, this is preferred.
 - Otherwise, to manually set the date and time, the automatic time synchronization service must first be disabled.

7.7 Serial Output Tab



WILDLIFE
ACOUSTICS

SMART Control Panel (System Name: TestSystem007)

DEVICES

DATA FILES

SETTING PROFILES

SCHEDULE PROFILES

TIME AND LOCATION

SERIAL OUTPUT

SCADA

NETWORKING

MAINTENANCE

ADMINISTRATION

Serial Output Apply Changes

Port

Data Bits

Parity

Prepend To Event Line

End Event Line With

Polling Seconds

Prepend To Poll Line

End Poll Line With

Stop Bits

Baud Rate

Select Event Fields

<input checked="" type="checkbox"/> Prefix	<input checked="" type="checkbox"/> Fmin
<input checked="" type="checkbox"/> Date	<input checked="" type="checkbox"/> Fmean
<input checked="" type="checkbox"/> Time	<input checked="" type="checkbox"/> TBC
<input checked="" type="checkbox"/> Duration	<input type="checkbox"/> Fk
<input checked="" type="checkbox"/> N	<input type="checkbox"/> Tk
<input checked="" type="checkbox"/> Fc	<input type="checkbox"/> S1
<input checked="" type="checkbox"/> Sc	<input type="checkbox"/> Tc
<input checked="" type="checkbox"/> Fmax	<input type="checkbox"/> Dur
	<input type="checkbox"/> CRC7

Select Poll Fields

<input type="checkbox"/> Date	<input type="checkbox"/> Events
<input type="checkbox"/> Time	<input type="checkbox"/> Voltage
<input type="checkbox"/> Disk	<input type="checkbox"/> CRC7

Version 1.0.5
© 2022 Wildlife Acoustics, Inc.

- The SMART System can provide near real-time streaming of bat analysis event data and periodic system status via serial port output.

NOTE: The purpose of the Serial Output tab is for configuration of this specific function. In addition to real-time streaming of bat analysis data, the SMART System serial interface has the potential for many other applications.

- The base model SMART Controller includes two DB-9 serial port connections. Either port can be used for Serial Output.
- On the web interface, the serial ports are identified as ttyS0 and ttyS1 (corresponding to their Linux device names).
- The corresponding DB-9 serial ports are identified [here](#).
- Press the **Apply Changes** button to update the SMART System with the current Serial Output settings.
- There are two kinds of messages which can be transmitted from the serial port, Event Messages and Polling Messages discussed in the next sections.

Serial Port Output When Results.csv is Updated (Event Messages)

- Event messages are output each time a **results.csv** file is updated from one of the streaming microphone devices.
- Any event message can begin with optional text ("**Prepend to event line**") followed by one or more comma separated fields.
- Fields are enabled by checking the corresponding box:
 - Prefix - Detection event name prefix
 - Date - Datestamp of the detection YYYY-MM-DD
 - Time - Timestamp of the detection hh:mm:ss.uuuuuu (uuuuuu are microseconds)
 - Duration - Duration of the detected signal event in seconds
 - N - Number of detected pulses. This is used to derive average values for the following:
 - Fc - Average characteristic frequency (kHz)
- The body of the call is the portion of the call consisting of the flattest slope where the characteristic frequency is typically the frequency at the latest part of the call body.
 - Sc - Average characteristic slope (Octaves per Second)
 - This is the slope of the body of the call.
 - Positive values correspond to decreasing frequency while negative values correspond to increasing frequency.
 - Fmax - Average maximum frequency (kHz)
- Maximum frequency detected in the call
 - Fmin - Average minimum frequency (kHz)
 - Minimum frequency detected in the call
 - TBC - Average time between calls (ms)
 - If N above is greater than one, this is the average period of the calls from the start of one call to the start of the next.
 - Fk - Average frequency of the knee (kHz)
 - Frequency at the beginning of the call body
 - Tk - Average time to the knee (ms)
 - Time from the beginning of the call to the beginning of the call body
 - S1 - Average initial slope (octaves per second)
 - Initial slope of the call.
 - Tc - Average time to the characteristic (ms)
 - Time from the beginning of the call to the end of the call body
 - Dur - Average duration (ms)
 - Duration of the call
 - CRC7 - The CRC7 is an optional 2-character (hexadecimal) checksum
- The event message line can be terminated with the "**End event line**" string (default is "\r\n" representing CRLF).

Serial Port Output At Specified Intervals (Polling Messages)

Polling messages can be output at a specified polling rate.

- **Polling Seconds** - Indicates how often a polling message is generated. (0 disables polling messages).
- **Prepend to poll line** The polling message can begin with optional text followed by one or more comma separated fields.
- Enable additional fields by checking the corresponding box:
 - Date - Date of poll message YYYY-MM-DD
 - Time - Time of poll message hh:mm:ss
 - Disk - Percent full of primary disk storage in the SMART controller
 - Events - Number of event messages generated since the last polling period
 - Voltage - The measured voltage at the SMART controller e.g. 12.0V
 - CRC7 - The CRC7 is an optional 2-character (hexadecimal) checksum
- The polling line can also be terminated with "**End Poll Line With**" string (default is "\r\n" representing CRLF).

7.8 SCADA Tab

The SMART system provides **Supervisory Control And Data Acquisition (SCADA)** integration and functions.

SMART supports **Modbus/TCP** (a version of Modbus that runs over TCP/IP networks e.g. over Ethernet or even WiFi) as well as **Modbus/RTU** (a version of Modbus that runs over serial connections using RS-232 or RS-422 or RS-485 serial connections).

The Modbus protocol allows a SCADA system (client) to connect to the SMART system (server). Modbus is a protocol which allows the client to read or write different kinds of registers from the server.

SMART provides up to 8 user defined Alarms which match bat call parameters at the pass and individual pulse levels. Alarms define simple conditional expressions.

Additional Criteria can be added to further refine each Alarm.

The SCADA client can read the pass and pulse alarm status for each alarm, (as well as other registers) and can use that as input in its decision making process about curtailment.

Alarm events are written to a smart-scada-log.txt file as they occur. The smart-scada-log.txt file can be viewed and downloaded from the Data Tab.

Once SCADA has been configured, you can also use OPC UA to communicate with the SMART Controller. See section 9.

Basic Settings

The basic settings under the SCADA Tab enable and configure the SMART server to be addressed by the SCADA client.

The Modbus Port is initially Disabled and can be configured for "TCP" to use Modbus/TCP or "ttyS0" or "ttyS1" for Modbus/RTU over a serial port.

NOTE: For a description of supported Modbus registers click [Here](#).

Modbus Port

Values: Disabled, TCP, ttyS0, ttyS1

Default: Disabled

For serial communications, the Server ID, baud rate, parity, start bits and stop bits are used to configure the serial interface and protocol parameters.

Server ID

Values: Not Specified

Default: 1

Baud Rate

Values: 50, 75, 110, 134, 150, 200, 300, 600, 1200, 1800, 2400, 4800, 9600, 19200, 38400, 57600, 115200, 230400

Default: 9600

Parity

Values: None, Even, Odd

Default: None

Data Bits

Values: 5, 6, 7, 8

Default: 8

Stop Bits

Values: 1, 2

Default: 1

Alarms

- An Alarm is a set of criteria based on Pass and/or Pulse filter settings
- When an Alarm is triggered, the corresponding Modbus register is updated to reflect the current condition
- The external SCADA system can poll the Modbus registers to acquire the current status of all alarms
- The external SCADA system can then use the Alarm status as an input for its curtailment logic
- Up to 8 Alarms can be created to run simultaneously and in parallel
- The SMART Web Interface allows selection and display of one alarm at a time
- Alarm Criteria can be created to fine tune the alarm conditions
- Select the Alarm to be viewed and edited with the **Select Alarm** menu
- Press **Clear Settings** to clear all parameters for the currently displayed Alarm
- Press **Apply Changes** to save the Alarm settings

Select Alarm

Values: Alarm 1-8

Default: Select Alarm

Pass Settings

The "Pass" alarm operates on a trigger-by-trigger bat pass basis using the average call parameters across the pass. The "Pass" alarm is equivalent to looking at the results.csv file as each trigger is detected and analyzed.

Pass Period (s)

- This sets the length of the Pass Period in seconds
- The Pass Period is a rolling and continuous window of time
- SMART keeps track of the number of bat passes which meet the alarm requirements within the Pass Period

Pass High Water

- If the number of bat passes within the Pass Period exceeds the specified Pass High Water number, the corresponding pass alarm condition is raised

Pass Low Water

- The alarm condition persists until the number of bat passes per Pass Period drops below the specified Pass Low Water number

Pulse Settings

The "Pulse" alarm operates on individual pulses as they are detected while building up a pass. The "Pulse" alarm looks at one pulse at a time to target specific patterns.

Pulse Period (s)

- This sets the length of the Pulse Period in seconds
- The Pulse Period is a rolling and continuous window of time
- SMART keeps track of the number of bat pulses which meet the alarm requirements within the Pulse Period

Pulse High Water

- If the number of bat pulses within the Pulse Period exceeds the specified Pulse High Water number, the corresponding pulse alarm condition is raised

Pulse Low Water

- The alarm condition persists until the number of bat pulses per Pulse Period drops below the specified Pulse Low Water number

Alarm Criteria

- Alarm Criteria are additional conditions used to further refine each alarm
- Each Alarm has separate Alarm Criteria

Alarm Criteria Examples

- An alarm criteria is a boolean (true or false) expression
- An expression can be a numeric comparison using these operators:
 - = equal to
 - != not equal to
 - <> not equal to (an alternative to the above)
 - < less than
 - <= less than or equal to
 - > greater than
 - >= greater than or equal to
- The above operators work on numeric expressions which can be any of the following:
 - A positive or negative number which can be an integer or floating point. **Examples:**
 - 1
 - 1.1
 - .1
 - -1
 - -.1
 - -1.1
 - A bat pulse or pass parameter (case insensitive e.g. you can say Fc, FC, fC, fc). For pass alarms, these values are the average parameter values across all pulses in a pass. For pulse alarms, they are the parameters for individual pulses.
 - N number of pulses in a pass (forced to 1 for pulse alarms)
 - Fc characteristic frequency in Hz
 - Sc characteristic slope in OPS
 - Fmax maximum frequency in Hz
 - Fmin minimum frequency in Hz
 - Fmean mean frequency in Hz
 - TBC time between calls in s (forced to 0 for pulse alarms)
 - Fk frequency of the knee in Hz
 - Tk time of the knee in s
 - S1 initial slope in OPS
 - Tc time of characteristic in s
 - Dur duration of pulse in s
 - A numeric value based on addition, subtraction of numbers and/or parameters. **Examples:**
 - Fmax - Fmin
 - Dur + 0.01
 - A numeric value enclosed by parentheses. **Example:**
 - (Fmax - Fmin)
 - An expression can also match the Prefix for exact match or for a substring match
 - The parameter "prefix" is a string and can be compared with another string
- A string constant can be specified using single or double quotes. **Examples:**
 - "This is a string"
 - 'this is a string'

- Strings can be compared for equality (case sensitive). **Example:**
 - Prefix = 'High Tower 3'
- Strings can be searched for a substring using the "~" operator. **Example:**
 - Prefix ~ 'High'
- Boolean expressions can be combined with "AND" and "OR" (these keywords are also case insensitive). **Examples:**
 - Fc > 40000 AND Prefix ~ 'High'
 - Fc > 20000 OR Dur > 0.005
- Boolean expressions can be grouped with parentheses. **Example:**
 - (Fc > 20000 OR Dur > 0.005) AND Prefix ~ 'High'
- Boolean expressions can be reversed with the "NOT" operator. **Example:**
 - NOT Fmax - Fmin < 1000
- Alarm expressions can include comments for readability. A comment is indicated with a '#' through the rest of the line. **Example:**
 - Fmax - Fmin > 1000 # only include calls with more than 1kHz bandwidth OR Fmax > 50000 # excluding calls above 50kHz which might be horseshoe bats

Complete Alarm Example

Here is a possible example of an alarm scenario:

Two microphones are deployed - one with prefix "High Mic 123" and one with prefix "Low Mic 456". In this example there is an interest in bats with a characteristic frequency between 35-45kHz. Also in this example there are narrowband noise

sources where there is 1500Hz of bandwidth prominent in mechanical squeaking noises. It is important that horseshoe bats (also narrowband) are not alarmed if the signal is above 50kHz.

In this example, two alarms are implemented. Alarm #1 is specified to indicate activity at the high microphone. Alarm #2 is specified to indicate activity at the low microphone. The following is the Alarm Criteria for Alarm #1:

Prefix ~ "High" # for high mic activate
 and (Fmax - Fmin > 1500 # and at least 1.5kHz bandwidth
 or Fmax > 50000 # or above 50kHz (e.g. don't alarm narrowband horseshoes))
 and Fc > 35000 and Fc < 45000 # interested in bats with characteristic frequency between 35-45kHz

Next, in this example an alarm condition will raised if there are more than 25 matching pulses in a one minute interval. This is done by setting the Pulse Period to 60 seconds, and the pulse high-water mark to 25. To keep the alarm condition active until no bats are detected for a 1 minute period, the pulse low-water mark is set to 0.

Select Alarm
 Alarm 1 Clear Settings

<p>Pass Settings</p> <p>Pass Description <input type="text"/></p> <p>Pass Period (s) <input type="text"/></p> <p>Pass High Water <input type="text"/></p> <p>Pass Low Water <input type="text"/></p>	<p>Pulse Settings</p> <p>Pulse Description High mic bat pulses 35-45</p> <p>Pulse Period (s) 60</p> <p>Pulse High Water 25</p> <p>Pulse Low Water 0</p>
-----------------------------------------------------------------------------------------------------------------------------------------------------------------------------------------------------------------------------	--------------------------------------------------------------------------------------------------------------------------------------------------------------------------------

Alarm Criteria

Prefix ~ "High"
 # for high mic activate and (Fmax - Fmin > 1500
 # and at least 1.5kHz bandwidth or Fmax > 50000
 # or above 50kHz (e.g. don't filter narrowband horseshoes))
 and Fc > 35000 and Fc < 45000
 # interested in bats with characteristic frequency between 35-45kHz

Select Alarm
 Alarm 2 Clear Settings

<p>Pass Settings</p> <p>Pass Description Generic low mic bat activity</p> <p>Pass Period (s) 60</p> <p>Pass High Water 2</p> <p>Pass Low Water 0</p>	<p>Pulse Settings</p> <p>Pulse Description <input type="text"/></p> <p>Pulse Period (s) <input type="text"/></p> <p>Pulse High Water <input type="text"/></p> <p>Pulse Low Water <input type="text"/></p>
-----------------------------------------------------------------------------------------------------------------------------------------------------------------------------	----------------------------------------------------------------------------------------------------------------------------------------------------------------------------------------------------------------------------------

Alarm Criteria

Prefix ~ "Low"

The following Modbus registers can be addressed by a SCADA system:

Function Code	Address (decimal)	Description (where N is a digit from 1 through 8 for filter # N) And X is any digit 0-9.
2	1 0000N	Alarm #N bat pass alarm (1 = alarm present, 0 = no alarm)
2	1 0001N	Alarm #N bat pulse alarm (1 = alarm present, 0 = no alarm)
2	1 0002X	Reserved for customization
3/6/16	4 000N1	Pass Alarm #N number of rolling seconds for bat pass alarm period
3/6/16	4 000N2	Pass Alarm #N minimum number of bat passes per period to set alarm (high water)
3/6/16	4 000N3	Pass Alarm #N maximum number of bat passes per period to clear alarm (low water)
3/6/16	4 000N4	Pulse Alarm #N number of rolling seconds for bat pulse alarm period
3/6/16	4 000N5	Pulse Alarm #N minimum number of bat pulses per period to set alarm (high water)
3/6/16	4 000N6	Pulse Alarm #N maximum number of bat pulses per period to clear alarm (low water)
3/6/16	4 0009X	Reserved for customization
4	3 00001	Disk utilization (0-100 %)
4	3 00002	Memory utilization (0-100 %)
4	3 00003	CPU utilization (0-100 %)
4	3 00004	Voltage (0.1V)
4	3 000N1	Pass Alarm #N bat pass event counter (modulo 65536)
4	3 000N2	Pass Alarm #N bat pass events per period
4	3 000N3	Pass Alarm #N seconds since most recent pass event (up to 65535)
4	3 000N4	Pass Alarm #N bat pass alarm counter (modulo 65536)
4	3 000N5	Pulse Alarm #N bat pulse event counter (modulo 65536)
4	3 000N6	Pulse Alarm #N bat pulses per period
4	3 000N7	Pulse Alarm #N seconds since most recent pulse event (up to 65535)
4	3 000N8	Pulse Alarm #N bat pulse alarm counter (modulo 65536)
4	3 00N01	Pass Alarm #N most recent value N (number of pulses in pass)
4	3 00N02	Pass Alarm #N most recent value Fc (characteristic frequency, 10Hz)
4	3 00N03	Pass Alarm #N most recent value Sc (Slope of characteristic, OPS)
4	3 00N04	Pass Alarm #N most recent value Fmax (maximum frequency, 10Hz)
4	3 00N05	Pass Alarm #N most recent value Fmin (minimum frequency, 10Hz)
4	3 00N06	Pass Alarm #N most recent value Fmean (mean frequency, 10Hz)
4	3 00N07	Pass Alarm #N most recent value TBC (time between calls, 0.1ms)
4	3 00N08	Pass Alarm #N most recent value Fk (frequency of knee, 0.1ms)
4	3 00N09	Pass Alarm #N most recent value Tk (time of knee, 0.1ms)
4	3 00N10	Pass Alarm #N most recent value S1 (initial slope, OPS)
4	3 00N11	Pass Alarm #N most recent value Tc (time of characteristic, 0.1ms)
4	3 00N12	Pass Alarm #N most recent value Dur (pulse duration, 0.1ms)
4	3 009XX	Reserved for customization

7.9 Networking Tab

The Networking tab of the web interface displays status and provides customization for the network configuration of the SMART System. We strongly recommend engaging with the Information Technology (IT) personnel of your organization for network set up assistance.

The screenshot displays the 'SMART Control Panel (System Name: TestSystem007)' with the 'Networking' tab selected. The interface is divided into several sections:

- Network Configuration:** Includes a dropdown for 'Basic Network Configuration' and an 'Apply Changes' button.
- Ethernet Configuration:** Features a dropdown for 'Dynamic IP (via DHCP)'.
- Wi-Fi Configuration:** Features a dropdown for 'Access Point'.
- Static IP Configuration:** Includes fields for 'SSID', 'Password', 'Static IP' (dropdown), 'IP Address', 'Mask bits (0-32)', and 'Default Gateway IP'.
- Name Server Configuration:** Includes fields for 'Primary Name Server IP' and 'Secondary Name Server IP'.
- DHCP Server Configuration:** Features a dropdown for 'Enabled' and fields for 'Subnet IP Address' (192.168.1.0), 'Subnet IP Netmask' (255.255.255.0), 'IP Range From' (192.168.1.128), 'IP Range To' (192.168.1.192), 'Default Route IP', and 'Primary Name Server IP'.
- Secondary Name Server IP:** A field for the secondary name server IP.
- Interface Status:** A section at the bottom showing network interface details, including 'br0: flags=4163<UP,BROADCAST,RUNNING,MULTICAST> mtu 1500'.

NOTE: Network configuration should only be edited by an experienced network technician.

- The SMART Controller provides two independent network interfaces – Ethernet and WIFI.
- Each interface can be independently configured for a variety of uses.
- The network configuration is defined by a “netplan”. The netplan is a Linux-specific configuration file.
- The netplan can be edited and applied via the Basic Network Configuration view or the Advanced Network Configuration view.
- The SMART Controller ships with a default netplan.
 - The default netplan of the SMART Controller configures the Ethernet port to use DHCP to acquire it's configuration from a network DHCP server.
 - The default netplan of the SMART Controller configures the on-board WIFI as a network HotSpot access point.

NOTE: If there is some sort of network connection problem the SMART Controller is always accessible via direct monitor and keyboard control. It is then possible to reset the SMART Controller to the default netplan. For command-line instructions for resetting the default netplan, check [Additional Resources](#).

Basic/Advanced Network Configuration

The Networking tab provides two views for editing settings. The following section describes the Basic Network Configuration view.

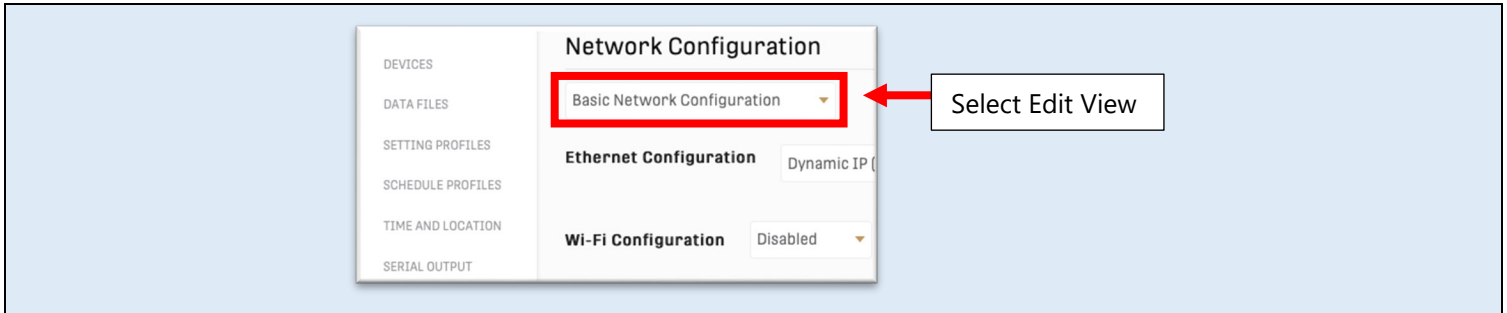

- The Basic Network Configuration view provides editing functions for a specific subset of the netplan.
- The enp6s0 Ethernet configuration (which is the main Ethernet port) and the WIFI configuration can be edited under the Basic Network Configuration.
- Pressing the Apply Changes button updates the underlying netplan.
- The Advanced configuration view provides for editing of the raw Linux netplan.

Ethernet Configuration

The Ethernet port connection on the SMART Controller is RJ45 Port 1 (non-PoE).

- The Ethernet port can be configured for **Dynamic** address.
 - If the Ethernet port is set to Dynamic IP it will acquire its IP address via DHCP, typically from the local router.
- The Ethernet port can be configured to **Static IP**.

The following Static IP parameters are set manually:

- IP Address
- Mask Bits (0-32)
- Default Gateway IP (Router address)
- Primary Name Server IP (DNS Server)
- Secondary Name Server IP (DNS Server)

NOTE: In the default configuration, the SMART Controller WiFi provides an access point for SSID "smart-xxxxxxxxxx" (where xxxxxxxxxxxx is the unique MAC address of the SMART's primary Ethernet interface). You can join this network and then browse to 192.168.19.1 to access the SMART Controller's web-based user interface. If you plan to simultaneously connect the SMART Controller's Ethernet interface to a second network, it must not conflict with the 192.168.19.0/24 subnet. If there is a conflict, you can change the subnet of the SMART Controller's WiFi access point, change the SMART Controller's WiFi to client mode (and connect to a different WiFi network), or disable the SMART Controller WiFi completely.

NOTE: The SMART System requires a DNS server if the Wildlife Acoustics gateway feature is being used to look up and connect to the gateway's IP address.

NOTE: The default netplan configures the RJ45 Ethernet port to use DHCP to acquire its configuration from a network DHCP server. This means if the Ethernet port is connected to a local network through a router it will be available to that network. If the network is connected to the Internet, the SMART System will be ready to configure and connect to the SMART Gateway.

WiFi Configuration

The WiFi port on the SMART Controller can be set to:

- Disabled
 - The WiFi interface is completely disabled.
- Access Point
 - WiFi is configured so the SMART Controller becomes a network Access Point for other devices.
- Client Device
 - The SMART Controller WiFi is configured as a device that can connect to a WiFi access point.

The following fields are displayed when Access Point or Client Device is selected.

- SSID and Password

- These describe the specific wireless network to be created (access point) or joined (client device).
- Dynamic IP
 - The IP address will be assigned dynamically by a DHCP server.
- Static IP
 - The following are configured manually:
 - IP Address
 - Mask Bits (0-32)
 - Default Gateway IP
 - Primary Name Server IP
 - Secondary Name Server IP

NOTE: The default netplan configures the SMART Controller WIFI as an access point. The default static address 192.168.19.1/24. There is no default router or DNS. The purpose of the default configuration is for direct connection from a laptop to the SMART Controller for initial configuration.

DHCP Server Configuration

- If the DHCP server Configuration is disabled The SMART Controller will not provide any IP addresses.
- If the DHCP server Configuration is enabled, The SMART Controller can implement a DHCP server.
 - This is primarily used to configure the SMART WIFI to be a convenient access point for laptop computers.

The DHCP server function requires the following:

- Subnet IP Address
 - This specifies the subnet for which dynamic addresses will be allocated.
- Subnet IP netmask
 - The SMART System uses the dotted quad notation of 255.255.255.0 for the network mask.
- IP Range From
- IP Range To
 - Specify a range of IP addresses that the DHCP server will allocate for its clients. These addresses must all be within the same subnet.
- Default route IP (Optional)
 - Typically this will be the same as the SMART WIFI IP address so the SMART Controller is the next-hop router for WIFI clients who may then also connect to the Internet through the Ethernet port.
- Primary Name Server IP
- Secondary Name Server IP
 - Up to two DNS servers can be specified to advertise to the DHCP clients for their use.

NOTE: The default DHCP server settings are matched with the default WIFI network settings. Specifically, the subnet IP address is 192.168.19.0, the netmask is 255.255.255.0, the default route is 192.168.19.1, and the range of addresses available to allocate to clients is 192.168.19.128 to 192.168.19.192.

Interface Status

Current status of all network functions are displayed.

<p>SCHEDULE PROFILES</p> <p>SERIAL OUTPUT</p> <p>SCADA</p> <p>NETWORKING</p> <p>MAINTENANCE</p> <p>ADMINISTRATION</p>	<h3>Interface Status</h3> <pre>br0: flags=4163<UP,BROADCAST,RUNNING,MULTICAST> mtu 1500 inet 169.254.146.70 netmask 255.255.0.0 broadcast 169.254.255.255 inet6 fe80::4e38:d5ff:fe11:e25c prefixlen 64 scopeid 0x20<link> ether 4c:38:d5:11:e2:5c txqueuelen 1000 (Ethernet) RX packets 1377182 bytes 63350372 (63.3 MB) RX errors 0 dropped 0 overruns 0 frame 0 TX packets 1377572 bytes 41343208 (41.3 MB) TX errors 0 dropped 0 overruns 0 carrier 0 collisions 0 enp6s0: flags=4163<UP,BROADCAST,RUNNING,MULTICAST> mtu 1500 inet 192.168.1.11 netmask 255.255.255.0 broadcast 192.168.1.255 inet6 fe80::4e38:d5ff:fe11:e25a prefixlen 64 scopeid 0x20<link> ether 4c:38:d5:11:e2:5a txqueuelen 1000 (Ethernet) RX packets 1090338 bytes 235644444 (235.6 MB) RX errors 0 dropped 0 overruns 0 frame 0 TX packets 221077 bytes 16187379 (16.1 MB) TX errors 0 dropped 0 overruns 0 carrier 0 collisions 0 device memory 0x91500000-915fffff</pre>
------------------------------------------------------------------------------------------------------------------------------	---------------------------------------------------------------------------------------------------------------------------------------------------------------------------------------------------------------------------------------------------------------------------------------------------------------------------------------------------------------------------------------------------------------------------------------------------------------------------------------------------------------------------------------------------------------------------------------------------------------------------------------------------------------------------------------------------------------------------------------------------------------------------------------------------------------------------------------------------------------------------------------------------------------------------------------------------------------------------------------------------------------

7.10 Maintenance Tab

Maintenance
Apply Changes

Start Of Daily Maintenance Window Hour Minute

After Maintenance, Power Down Until Hour Minute

Note If finished after this time and before above start time, then no power down

Copy Data To External USB drive, If Available

CSV Files
 Log Files
 WAV/W4V Files
 ZC File

Copy Data To Network Via Rsync

CSV Files
 Log Files
 WAV/W4V Files
 ZC Files

Destination
Password

Send Test File

File Management

<p>Rotate CSV Results And Logs (days)</p> <input style="width: 100%;" type="text" value="90"/>	<p>Keep CSV Results And Logs (days)</p> <input style="width: 100%;" type="text" value="365"/>
<p>Delete WAV/W4V Files After (days)</p> <input style="width: 100%;" type="text" value="90"/>	<p>Delete ZC Files After (days)</p> <input style="width: 100%;" type="text" value="365"/>

Email configuration

To Email
Subject

Send Test Email

The SMART System can be configured to enter a daily Maintenance mode.

After maintenance is performed (and a 5 minute delay to guarantee a window when the SMART System is accessible over the network), the SMART System can be shut down until a specified wake-up time in order to conserve power.

The SMART System will not be accessible during this shut down period without physically pushing the power button.

NOTE: To prevent the SMART System from shutting down after maintenance, set the "After maintenance, power down until" time to the same or earlier "Start of daily maintenance window" time.

NOTE: If the SMART system is powered via solar panels or battery, it is best practice to shut the SMART system down when it is not scheduled to be in use.

NOTE: If the SMART System is powered down by the Maintenance schedule, a Device schedule will not "wake up" the SMART system.

Start of daily maintenance window

Set the Hour and Minute each day when the SMART System will enter Maintenance mode.

After maintenance, power down until

Set the Hour and Minute each day when the SMART System will power back on.

Copy data to external USB drive if available

An external USB drive can be connected to the SMART Controller for file backup.

During the maintenance window, the first discovered USB hard drive will be mounted, files resynced to it, and then unmounted.

- Check each file type to include in the backup:
 - CSV Files
 - Log Files

- WAV/W4V Files
- ZC Files

Values: Enabled/Disabled

Default: All Enabled (Checked)

Copy data to network via rsync

The SMART System can transfer selected file types over the network via rsync to a remote host.

- Check each file type to include in the backup:
 - CSV Files
 - Log Files
 - WAV/W4V Files
 - ZC Files

Values: Enabled/Disabled

Default: All Enabled (Checked)

Destination: The user, host and path is specified

Password: An optional ssh password can all be specified.

- The www-data public ssh key is provided should that be necessary to set up remote server access.

To test the connection, press the **Send test file** button, which will send a file with the name "testfile_YYYYMMDD_hhmmss.txt" to the destination folder.

Rotate CSV results and logs (days)

CSV results files and logs can be rotated after a specified number of days.

Values: Not Specified

Default: 90

Keep CSV results and logs (days)

Values: Not Specified

Default: 365

Delete WAV/W4V files after (days)

Values: Not Specified

Default: 90

Delete ZC files after (days)

CSV files and log files, as well as WAV/W4V and ZC files, can be automatically deleted after a specified number of days.

Values: Not Specified

Default: 365

Email Configuration

A summary report is generated for each maintenance mode session.

The summary report is sent via email by way of the Wildlife Acoustics server.

The sender will be "SMART Mail Gateway <noreply@wildlifeacoustics.com>".

- To Email: (Can be multiple email addresses separated by semicolons ";")
- Subject: (Default: "SMART daily report")

Press the Send Test Email Button to Verify Correct Operation

- Here is an example of the automated email:

```
SMART Daily Report 2020-12-28 05:00:01

DEVICE STATUS
Prefix  Serial number Status # WAV # ZC MB used
-----
Low Tower 9c.25.be.01.00.29 streaming 5,210 5,210 10,325.043
High Tower 9c.25.be.01.00.18 streaming 5,512 5,512 10,002.840

Uptime: 05:00:02 up 16:02, 1 user, load average: 0.00, 0.22, 0.39
```

```
Mounting external drive /dev/disk/by-id/usb-PNY_PNY_PRO_ELITE_PS_511200818148D38200B4-0:0-part1...
FileSystem 1K-blocks Used Available Use% Mounted on
/dev/sdb2 60761956 25224076 32421644 44% /
/dev/sda1 976730112 931072 975799040 1% /mnt/smart-external

Synchronizing with external storage...

Synchronization to external storage completed

FileSystem 1K-blocks Used Available Use% Mounted on
/dev/sda1 976730112 25782784 950947328 3% /mnt/smart-external

Synchronizing with someuser@somehost.net:some/path/...

Synchronization to network storage completed

Cleaning up old files and rotating logs...

Clean up completed.

FileSystem 1K-blocks Used Available Use% Mounted on
/dev/sdb2 60761956 25544276 32101444 45% /

Finished daily maintenance at 2020-12-28 05:12:16 (735 seconds)
Sleeping until 06:30
```

Apply Changes

Press the Apply Changes button to update the SMART System with the current Maintenance settings.

Public ssh key for user www-data (provided here for convenience)

7.11 Administration Tab

WILDLIFE
ACOUSTICS

SMART Control Panel [System Name: TestSystem007]

Administration

Unix And Web Password For 'SMART'

Password

Password (Again)

Note If using WiFi, change SSID password in networking configuration

SMART System Name

System Name

Wildlife Acoustics IOT Gateway

Status Refresh Rate (Minutes)

Authorized Users (Email Addresses)

Enable

Upgrade or Install Package

Drop Files To Upload Or **Browse**

No file chosen

Note On success, the webserver may be restarted and your connection will be lost. Reload the page to see if the upgrade was successful.

Force Reboot

Note Reboots the SMART system. The system may be unresponsive for several minutes.

Version 1.0.2
© 2022 Wildlife Acoustics, Inc.

The Administration tab provides basic global functions for the SMART System. All authorized users with access to the SMART System have access to the Administration functions.

Unix and Web Password for 'smart'

The default password is "wildlife".

To change the default password:

1. Enter Password
2. Enter Password (again)
3. Press: **Change Password**

SMART System Name

The default SMART System name is "smart".

To change the System name:

1. Enter new system name

2. Press: **Change System Name**

Wildlife Acoustics IOT Gateway

Configure the SMART System for [Internet Gateway access](#).

Any changes made within the SMART system will be updated to the SMART Gateway. The refresh rate determines how often the status will be updated.

Status Refresh Rate (minutes)

Values: 1-Not Specified

Default: 60 minutes

Enter the Wildlife Acoustics web account email addresses for each authorized user of the SMART System Internet Gateway.

Authorized User (email addresses)

Values: Enter one or more WildlifeAcoustics.com web account email address, separated by commas.

Enable or Disable the SMART Gateway system.

The checkbox determines whether the SMART System is currently connected to the SMART Gateway.

1. Check to Enable/Uncheck to Disable
2. Press the **Apply Changes** button

Upgrade or Install Package

Wildlife Acoustics will make SMART System updates and Device firmware updates available periodically. The update will be in the form of a downloadable file.

A SMART System update may or may not include a SMART MIC-1 firmware update.

- If the SMART System update does include a SMART MIC-1 firmware update, an Update button will be available next to the SMART MIC-1 under the Devices tab, when the Device is Idle.

1. Press the **Choose File** button to locate the downloaded update file

The selected update file will now be listed

2. Press the **Upload and Install** button.

NOTE: On success, the webserver may be restarted and the connection to the SMART System will be lost. Reload the page to check that the update was successful.

Force Reboot

Pressing the **Reboot** button will restart the SMART System.

NOTE: Rebooting the SMART System will cause the system to be unresponsive for several minutes.

8 SMART Internet Gateway

The SMART System can be accessed through an Internet Gateway connection. This provides the capability for multiple authorized users to access the SMART system. The SMART Web Interface and command-line interface can both be initially accessed through the Gateway via the WildlifeAcoustics.com website. This then allows full access and control of the SMART System from any authorized device in any location which can access the Internet and open a web browser.

- When the Internet Gateway function is enabled, the SMART System will create an encrypted connection to a secure Internet Gateway service operated by Wildlife Acoustics.
- The Internet Gateway service uses encrypted communication and can be restricted to specific IP addresses for maximum security.
- The SMART System can connect to the SMART Internet Gateway via Ethernet or WIFI.
- The default configuration of the SMART System is set up so the Ethernet port on the SMART Controller will acquire its configuration from a network using DHCP.
 - If the Ethernet port on the SMART Controller is connected to the Internet, the SMART Controller will acquire an IP address and will be available for connection to the Internet Gateway.
 - If WIFI is to be used to connect to the Internet Gateway, that must be configured separately.
- The initial administrator of the SMART System can add or delete unlimited authorized users with Internet Gateway access. Authorized users have full access to the SMART System.
- The website interface allows each authorized user to configure and manage their access to the SMART System.

8.1 Connect the SMART System to the Internet

The default netplan configures the first RJ45 port on the SMART Controller for Ethernet connection to an existing network using the network's DHCP Controller.

- If a local Ethernet connection to the internet is available, all that is required to establish communication between the SMART Controller and the Internet is connection of the CAT5/6 cable. No further setup is required for this default configuration.

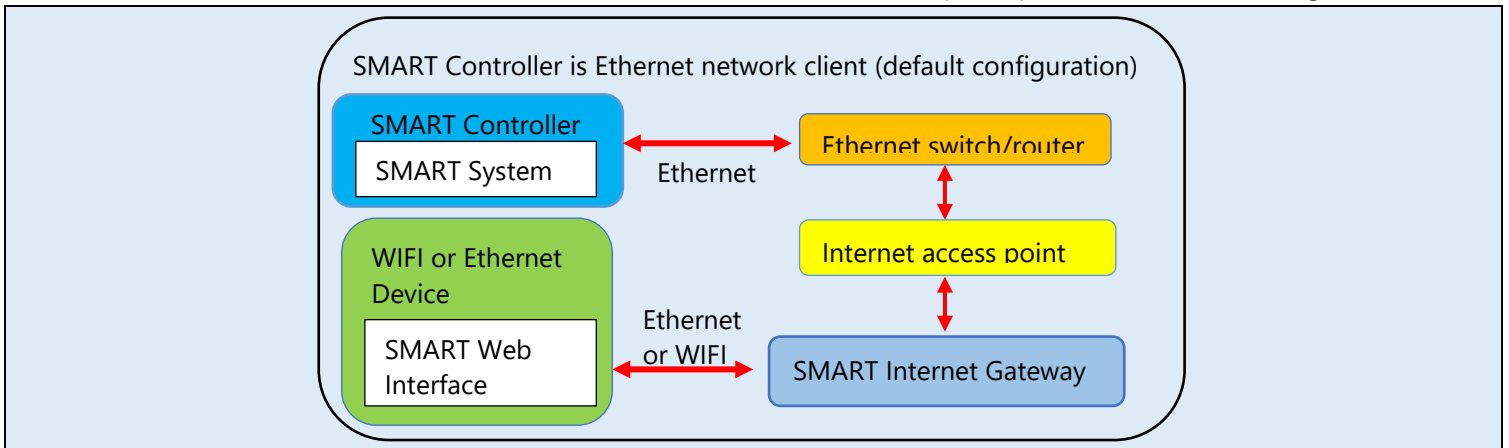

- In order to use the SMART Controller WIFI for Internet Gateway connection, the netplan must be configured to do so.

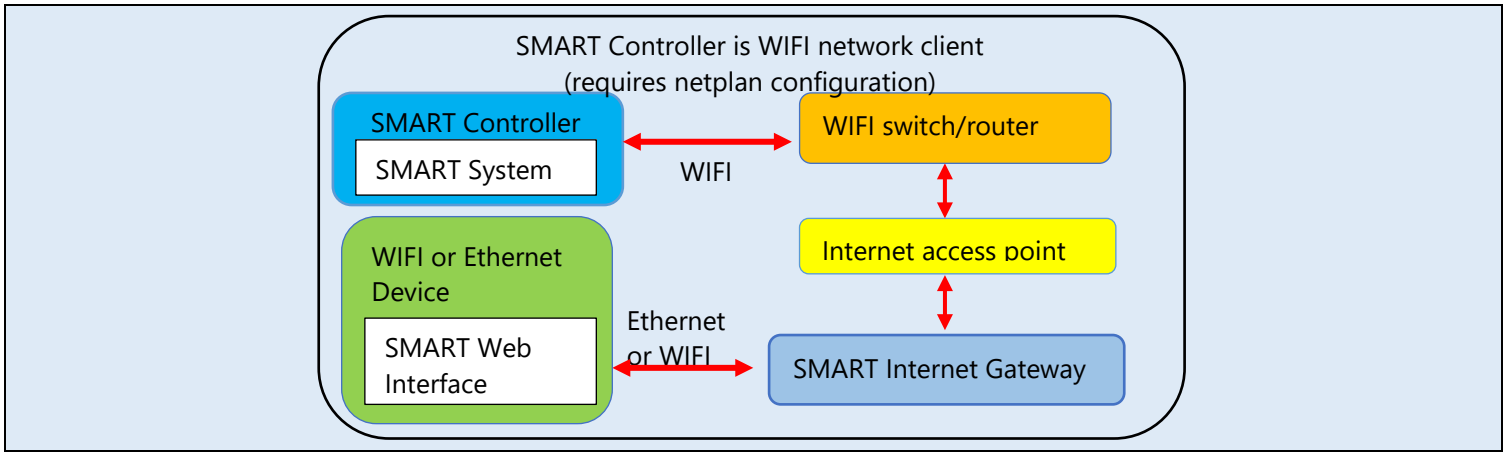

8.2 Configure the SMART System for Internet Gateway connection

1. Open the SMART Web Interface.
 - Follow the steps in the Quick Start to connect to the SMART Controller WIFI from a device which can run a web browser. Gateway access is configured under the [Administration tab](#).

Add or Delete Authorized User Access to the SMART System

2. Click on the Administration tab.
3. Under Wildlife Acoustics IOT Gateway, enter (or delete) the Wildlife Acoustics account email addresses of the users who will be authorized to have access to the SMART Controller.

NOTE: Each authorized user to have access to the SMART System must have a Wildlife Acoustics web account. A Wildlife Acoustics web account can be created here: <https://www.wildlifeacoustics.com/account/login>

- Only authorized users have access to a SMART System through the SMART Gateway.
- Authorized users can be added or deleted from SMART System Gateway access at any time.
- Adding or deleting authorized users is done under the Administration tab in the SMART web interface
- Any currently authorized user can add or delete other authorized users from the SMART System Gateway access.

Enable Internet Gateway Access to the SMART System

4. Check the **Enable** box
5. Press the **Apply Changes** button.
 - The SMART System is now configured to be accessed by the assigned authorized users.
 - To temporarily suspend SMART Gateway access from all authorized users to the SMART Controller, uncheck the Enable button and press the **Apply Changes** button.

8.3 Configure Gateway access through WildlifeAcoustics.com

The SMART System must be connected to the Internet in order to access the Wildlife Acoustics Internet Gateway. When the SMART System Gateway function is enabled, it will automatically try to establish a secure connection to the Wildlife Acoustics Internet Gateway.

- If connection fails (e.g. due to a network configuration problem or transient network outage etc.), it will automatically retry every 10 minutes.
1. Enable the Wildlife Acoustics IOT Gateway Under the Administration tab in the SMART Web Interface.
 2. Log on to any Wildlife Acoustics authorized user web account.
 - a. For each authorized user, there will now be a SMART Gateway tab on the left.
 - b. If there is no SMART Gateway tab in the user account, this means the Wildlife Acoustics managed gateway has not received authorization for that user account from the SMART System.

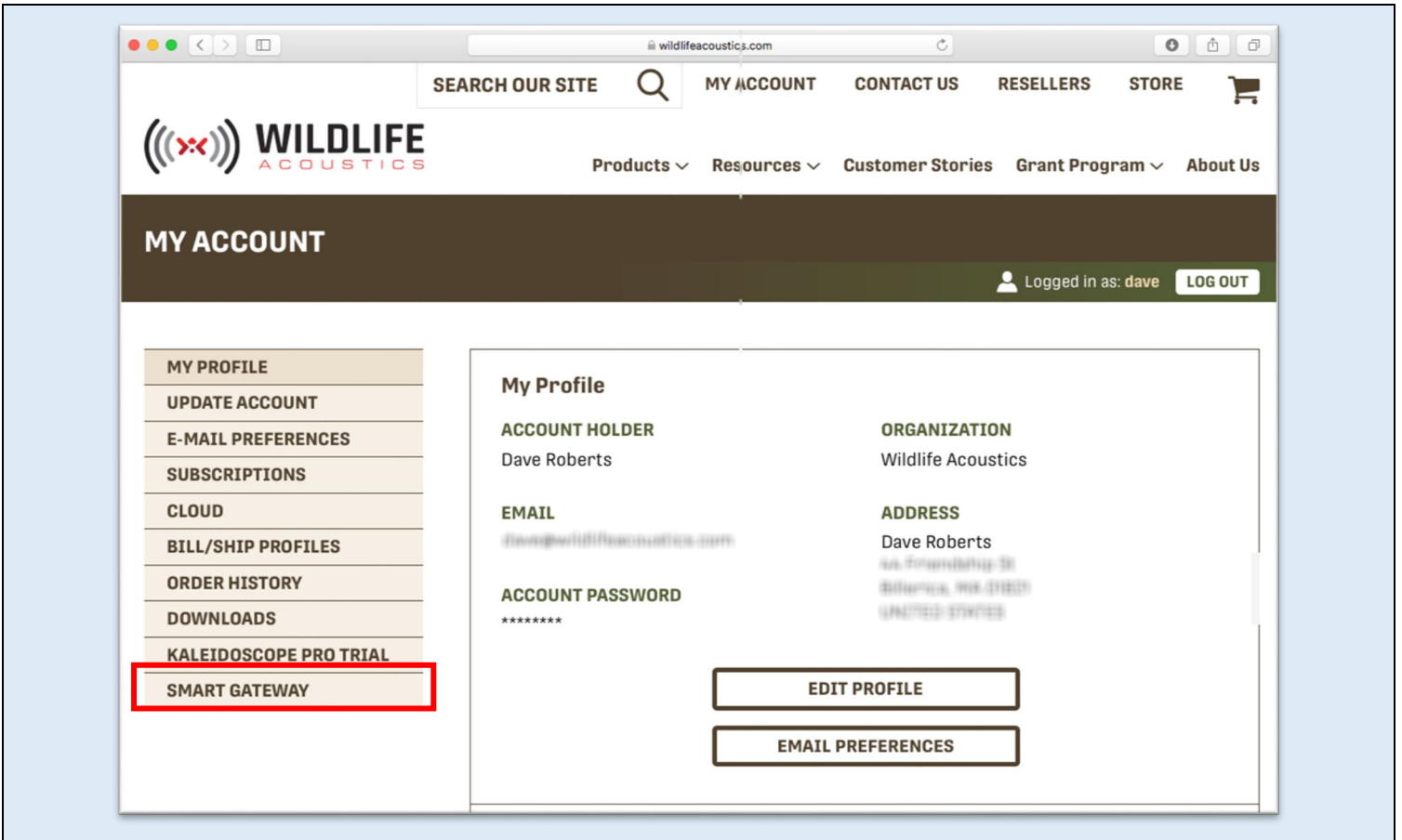

3. Click the SMART Gateway tab.

The SMART Portal will open.

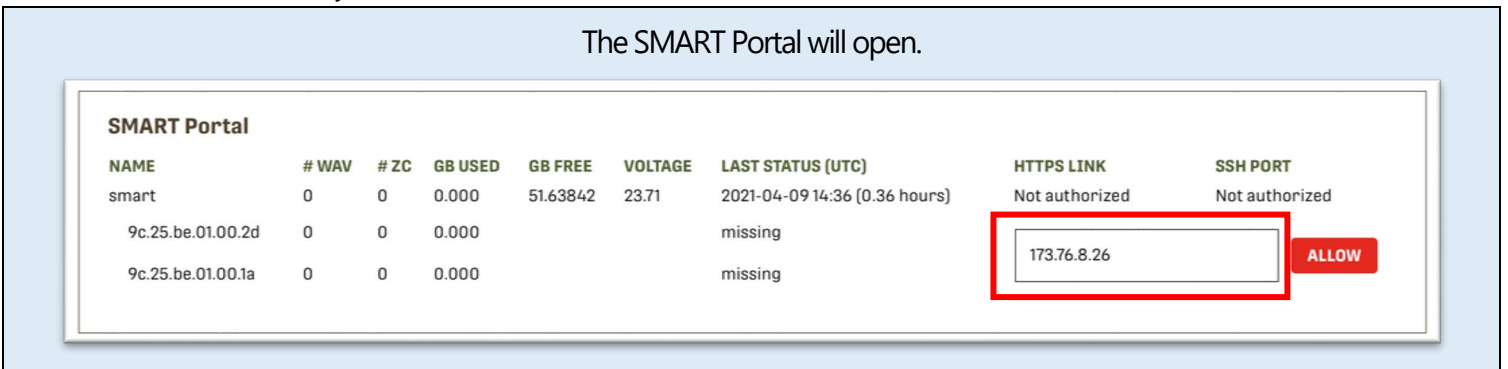

- a. The public IP address of the device currently running the web browser is displayed.
- b. Initially the IP address of the device accessing the SMART Gateway is not authorized. This is a security feature.
- c. Current status for each listed Device for the SMART System is displayed.
- d. If the user account is authorized for multiple SMART Systems, each system will be listed separately.

4. Click the Allow button to allow access to the SMART Gateway from the current device IP.
 - a. The HTTPS Link to the SMART System will now be displayed.

The SSH Port for command-line access will now be displayed

SMART Portal

NAME	# WAV	# ZC	GB USED	GB FREE	VOLTAGE	LAST STATUS (UTC)	HTTPS LINK	SSH PORT
smart	0	0	0.000	51.63842	23.71	2021-04-09 14:36 (0.37 hours)	https://173.76.8.26:443/	60749
9c.25.be.01.00.2d	0	0	0.000			missing		
9c.25.be.01.00.1a	0	0	0.000			missing	<input type="text" value="173.76.8.26"/> <input type="button" value="CHANGE"/> <input type="button" value="REVOKE"/>	

- b. To temporarily cease permission for the device IP address, press the Revoke button.
- c. It is possible to manually enter a local IP address or network address mask, and then press the Change button.
- d. If the SMART System is no longer connected with the Internet Gateway it is possible to delete the SMART System from the list.

SMART Portal

NAME	# WAV	# ZC	GB USED	GB FREE	VOLTAGE	LAST STATUS (UTC)	HTTPS LINK	SSH PORT
smart	0	0	0.000	51.63842	23.71	2021-04-09 14:36 (0.39 hours)	Not connected	Not connected
9c.25.be.01.00.2d	0	0	0.000			missing		
9c.25.be.01.00.1a	0	0	0.000			missing	<input type="text" value="173.76.8.26"/> <input type="button" value="CHANGE"/> <input type="button" value="REVOKE"/> <input type="button" value="DELETE"/>	

5. Click on the HTTPS Link.
6. Enter the SMART System username and password (Default user name is "smart". Default password is "wildlife")
7. The browser may display messages about not trusting the SSL/TLS certificate or other security concerns. Connect anyway. This is a secure connection.
8. The SMART Web Interface will now open.

9 OPC UA Communications Interface

9.1 OPC UA Introduction

OPC Unified Architecture (OPC UA) is a machine-to-machine communication protocol used for industrial automation developed by the OPC Foundation. The SMART Controller OPC UA interface provides a secure mechanism for retrieving status information, system updates and alarm notifications from a SMART device. OPC Clients are then able to take appropriate actions according to local needs, including bat curtailment processing. The Information Model used by the SMART Controller provides a flexible and comprehensive set of variables, methods and publish/subscribe features to enable full monitoring of a SMART system.

9.2 OPC UA Installation

This software update is provided as a single package file, *smart-18-1.3.1.deb* or *smart-22-1.3.1.deb*. The file is a linux installation file and can be installed using the SMART Web Portal's Administration Page. See section 7.11 for instructions on installing software updates.

9.3 OPC UA Configuration

- The OPC UA Server is run as a background daemon service named *smart-opcua*

- *smart-opcua* only starts if the file `/var/www/storage/scada.json` exists. This file is created when SCADA has been configured on the controller.
- You need to use Secure Certificates for communication between your client and the SMART Controller, and those may be installed in the SMART directory `/etc/ssl/private`. See the section “Connecting to the SMART Controller’s OPC UA Interface” below.

Helpful Shell Commands

The following are useful commands for controlling the OPC UA service from a terminal.

Command	Purpose
<code>systemctl start smart-opcua</code>	Start the opcua service
<code>systemctl stop smart-opcua</code>	Stop the opcua service
<code>systemctl restart smart-opcua</code>	Restart the opcua service
<code>journalctl -u smart-opcua -e -f</code>	“Tail” the opcua server log messages (use ctrl-c to stop the output)

9.4 Connecting to the OPC UA Interface

The SMART’s OPC UA Model is accessible from any client supporting the OPC UA standards (for example, the popular *UAExpert* client). The underlying interface is built from the [open62541](#) Server libraries and supports all of the OPC UA foundation’s commands and controls. The server supports OPC UA client/server communication, subscriptions, events, method calls and the full range of security paradigms (encryption). The controller’s Information Model is built upon the [OPC Foundation UA-Model Compiler](#) which utilizes the [UA Model Design.xsd](#) core file.

Connecting to a SMART device’s OPC UA server instance can be accomplished using any of the following URIs :

- **`opc.tcp://<hostname>.<domain>:4840`**
`<hostname>` is the SMART Controller’s hostname provisioned during system configuration. Using this URI assumes `<hostname>.<domain>` can be found using your local DNS queries.
- **`opc.tcp://<IP ADDRESS>:4840`**
Using this form of the URI assumes the client you are using has access to the SMART Controller’s `<IP ADDRESS>`
- Either of the above 2 formats can be used with openssl certificates.
 - The connection will abide by a Secure Certificate login, when the appropriate x.509 certificates are properly exchanged.
 - On first start, the server will auto-create self signed files `server_cert.der` and `server_key.pem` files in the `/etc/ssl/private` directory, if they do not already exist. You should copy these files to the appropriate location specified by your particular OPC UA client.
 - NOTE: You can have new certificates generated by the SMART Controller by removing the two certificate files and restarting the `smart-opcua` service (`systemctl restart smart-opcua`)
 - NOTE: The certificates generated by the SMART Controller are *self-signed*, and do not include any CA Trust authority. It is highly recommended you place your own certificates in the `/ec/ssl/private` directory (as the names “`server_cert.der`” and “`server_key.der`”) and restart the `smart-opcua` service.

Using openssl certificate methods mentioned above, these security policies & modes are supported:

- Basic128Rsa15 (Sign, SignAndEncrypt)
- Basic256 (Sign, SignAndEncrypt)
- Aes256_Sha256_RsaPas (Sign, SignAndEncrypt)
- Basic256Sha256 (Sign, SignAndEncrypt)
- Aes128_Sha256_RsaOaep (Sign, SignAndEncrypt)

Customizing Startup Arguments to `smart-opcua`

The `smart-opcua` service may be configured with additional startup options to suit the needs of your installation. For example, the default connection port of 4840 can be changed using the `--port` option.

Startup options can be modified in the `smart-opcua.opts` file which is located in the directory `/etc/defaults`. Simply edit the file and add the option(s) needed to the `SMART_OPSCUA_OPTS` setting.

The default *smart-opcua.opts* file:

```
# Default settings for smart-opcua
#
# Copyright (c) 2022 Wildlife Acoustics, Inc.
# All rights reserved.
#
# The opcua service accepts these options:
#
# --port          TCP Listen Port [4840]
# --certificate   Full path to the certificate .der file
[/etc/ssl/private/server_cert.der]
# --key          Full path to the private key .pem file
[/etc/ssl/private/server_key.pem]
# --secure-channel-trust-folder Full path to folder of secure channel trust certs
[/etc/ssl/private/trust]
# --session-trust-folder      Full path to folder of session trust certs
[/etc/ssl/private/trust]
#
# For example, to override the default listening port:
# SMART_OPCUA_OPTS="--port=35478"

SMART_OPCUA_OPTS=
```

Command line arguments to the smart-opcua application:

<code>--port</code>	The TCP port the server will accept connections from. DEFAULT: 4840
<code>--certificate</code>	Full path to server_cert.der file DEFAULT: /etc/ssl/private/server_cert.der
<code>--key</code>	Full path to server_key.pem file DEFAULT: /etc/ssl/private/server_cert.pem
<code>--secure-channel-trust-folder</code>	Full path to folder of secure channel trust certs DEFAULT: /etc/ssl/private/trust
<code>--session-trust-folder</code>	Full path to folder of session trust certs DEFAULT: /etc/ssl/private/trust

Modifying the Startup Options

If you need to modify any of the services' default settings such as the port number, perform these tasks while connected to the SMART from either a keyboard/monitor or an SSH session:

1. As root, edit the file */etc/default/smart-opcua.opts*
2. Edit the SMART_OPCUA_OPTS line and append the desired arguments. For example:
SMART_OPCUA_OPTS="--port=62541"
3. Save the file and restart the smart-opcua service
systemctl restart smart-opcua
4. Check the logs to ensure the service started
journalctl -u smart-opcua

9.5 SMART Controller Information Model

The SMART Information model files can be found in the directory `/usr/local/share/smart/opcu`.

- `smartModel.xml` - The UA Model file describing the SMART schema and variables
- `smartModel.csv` - A reference CSV file containing the node IDs for accessing nodes and variables from an OPC UA Client
- `Smart.NodeSet2.xml` - The raw NodeSet2 XML file with node IDs

The following images are a pictorial representation of the SMART Controller's OPC UA model:

▼ ● SmartController	2:SmartController	ns=2;i=15740
▼ ● Info	2:Info	ns=2;i=15741
> ☰ CpuUtilization	2:CpuUtilization	ns=2;i=15744
> ☰ DiskUtilization	2:DiskUtilization	ns=2;i=15743
> ☰ Hostname	2:Hostname	ns=2;i=15742
> ☰ MemoryUtilization	2:MemoryUtilization	ns=2;i=15745
> ☰ UpSinceDate	2:UpSinceDate	ns=2;i=15748
> ☰ UpTimeSeconds	2:UpTimeSeconds	ns=2;i=15747
> ☰ Voltage	2:Voltage	ns=2;i=15746
▼ ● PassAlarms	2:PassAlarms	ns=2;i=15749
▼ ● PassAlarm1	2:PassAlarm1	ns=2;i=15750
☰ AlarmPresent	2:AlarmPresent	ns=2;i=15754
> ☰ Dur_PulseDuration	2:Dur_PulseDuration	ns=2;i=15759
> ☰ Fc_CharacteristicFrequency	2:Fc_CharacteristicFreque...	ns=2;i=15760
> ☰ Fk_FrequencyOfKnee	2:Fk_FrequencyOfKnee	ns=2;i=15761
> ☰ Fmax_MaximumFrequency	2:Fmax_MaximumFreque...	ns=2;i=15762
> ☰ Fmean_MeanFrequency	2:Fmean_MeanFrequency	ns=2;i=15763
> ☰ Fmin_MinimumFrequency	2:Fmin_MinimumFreque...	ns=2;i=15764
> ☰ HighWater	2:HighWater	ns=2;i=15752
> ☰ LowWater	2:LowWater	ns=2;i=15753
> ☰ N_NumberOfPulses	2:N_NumberOfPulses	ns=2;i=15765
> ☰ PassAlarmCounter	2:PassAlarmCounter	ns=2;i=15758
> ☰ PassEventCounter	2:PassEventCounter	ns=2;i=15755
> ☰ PassEventsPerPeriod	2:PassEventsPerPeriod	ns=2;i=15756
> ☰ PassPeriod	2:PassPeriod	ns=2;i=15751
> ☰ S1_InitialSlope	2:S1_InitialSlope	ns=2;i=15766
> ☰ Sc_SlopeCharacteristic	2:Sc_SlopeCharacteristic	ns=2;i=15767
> ☰ SecondsSinceMostRecentPass...	2:SecondsSinceMostRec...	ns=2;i=15757
> ☰ TBC_TimeBetweenCalls	2:TBC_TimeBetweenCalls	ns=2;i=15768
> ☰ Tk_TimeOfKnee	2:Tk_TimeOfKnee	ns=2;i=15769
> ● PassAlarm2	2:PassAlarm2	ns=2;i=15770
> ● PassAlarm3	2:PassAlarm3	ns=2;i=15790
> ● PassAlarm4	2:PassAlarm4	ns=2;i=15810
> ● PassAlarm5	2:PassAlarm5	ns=2;i=15830
> ● PassAlarm6	2:PassAlarm6	ns=2;i=15850
> ● PassAlarm7	2:PassAlarm7	ns=2;i=15870
> ● PassAlarm8	2:PassAlarm8	ns=2;i=15890

SMART OPC UA defined Methods:

Method Name		Input	Output
ReadModbusRegister	Get the value of any MODBUS register	The MODBUS register number*	Register Value
ReadAllPassAlarms	Return the values for the 8 Pass Alarms	n/a	An array of 8 values for each Pass Alarm
ReadAllPulseAlarms	Return the values for the 8 Pulse Alarms	n/a	An array of 8 values for each Pulse Alarm

9.6 OPC UA Events

Your OPC client can subscribe to smart-opcu events published by the SmartController node (NodeId = 15740) in order to receive any OPC UA events that may occur. Examples of published events include when the value of a Bat Alarm (Pass or Pulse) changes from 1 to 0, or vice versa.

An event will be formatted with fields similar to the one below:

```
Event ([ 'ConditionSubClassName:None',
        'ConditionSubClassId:None',
        'ConditionClassName:None',
        'ConditionClassId:None',
        'Severity:100',
        "Message:LocalizedText (Locale='en-US', Text='Pass Alarm 1 Raised')",
        'LocalTime:None',
        'ReceiveTime:2023-12-28 01:18:20.609364',
        'Time:2023-12-28 01:18:20.609331',
        'SourceName:fdddde3df7dd',
        'SourceNode:NodeId (Identifier=15087, NamespaceIndex=2,
        NodeIdType=<NodeIdType.FourByte: 1>)',
        'EventType:NodeId (Identifier=15223, NamespaceIndex=2,
        NodeIdType=<NodeIdType.FourByte: 1>)',
        "EventId:b'1\\xf5\\x95\\x19\\xed\\n\\xc9\\xbd\\xcf\\x12;t\\x8f\\xf8\\x84\\x88'"] )
```

In addition to the events published from the SmartController node, your client can also subscribe to changes on any individual Pass or Pulse Alarm variable. You can monitor value changes to each Alarm variable in order to take action when the value changes.

10 Network Security

When a device is connected to an existing network, there is always a question of the security of that device. The Wildlife Acoustics SMART System is specifically designed to be secure when connected to a private or public network.

10.1 SMART System

The SMART Controller runs on top of an open Ubuntu Linux server environment. The SMART Controller can be configured in a similar way to any other secured device on a network. For example, it is possible to connect to a VPN with a private static IP and access the SMART Controller from other authorized VPN clients.

- The SMART System does not require the Wildlife Acoustics IOT gateway.
- The SMART Controller's web interface runs on Apache with SSL/TLS required. The Apache configuration files can be modified/changed to suite if there is a requirement to restrict access to certain cipher suites and algorithms.
- The SMART Controller's web interface is protected by BASIC Authentication over the encrypted connection. The password is user-specified.

- The SMART Controller's command line is available with SSH. Configuration files can be modified/changed to suite security requirements.

10.2 Wildlife Acoustics IOT Gateway

- Developed entirely by Wildlife Acoustics using OpenSSL.
- The server is hosted in AWS and the client runs on the SMART Controller.
- The SMART Controller establishes an AES128-SHA encrypted connection to the IOT gateway on a TCP connection.
- The SMART Controller and Gateway identify and authenticate each other with a SHA256 hash.
- The encrypted TCP connection can then multiplex multiple HTTPS and SSH encrypted tunnels between a SMART Controller and authorized clients (so these sessions are essentially double-encrypted).
- The Gateway maps two unique TCP ports as connection points to each connected SMART Controller, one for HTTPS traffic and one for SSH traffic.
- The Gateway will only allow connections from authorized IP addresses for a given SMART Controller as specified in the Wildlife Acoustics "My Account / Smart Gateway" page for an authorized user.
- Authorized users can authorize connections from their own current IP address, a subnet, or disable access. (The union of all authorized IP addresses from authorized users is allowed to make connections through the gateway to the specific SMART Controllers).
- The SMART Controller also sends basic status information to the gateway which is available to authorized users on the "My Account / Smart Gateway" page.

11 Specifications

11.1 SMART Controller Specifications

- 2-core Intel Atom x5-E930 (option for 4-core x7-E950)
- 4GB RAM (expandable to 8GB)
- 64GB SDD drive (options up to 1TB)
- Input power 9-36VDC, comes with a 120/240VAC power brick to use line voltage.
- 2 RS-232/422/485 COM ports
- 4 USB 3.0 ports
- 3-pin CAN bus
- 8-bit isolated digital I/O (4 in/4 out)
- 2 DisplayPorts
- 3 GbE LAN ports (2 w/ PoE for direct connection of up to two SMART microphone devices. Additional microphone devices can be supported with an external Ethernet PoE switch).
- WIFI 802.11ac (options for 4G LTE)

11.2 SMART Controller Dimensions

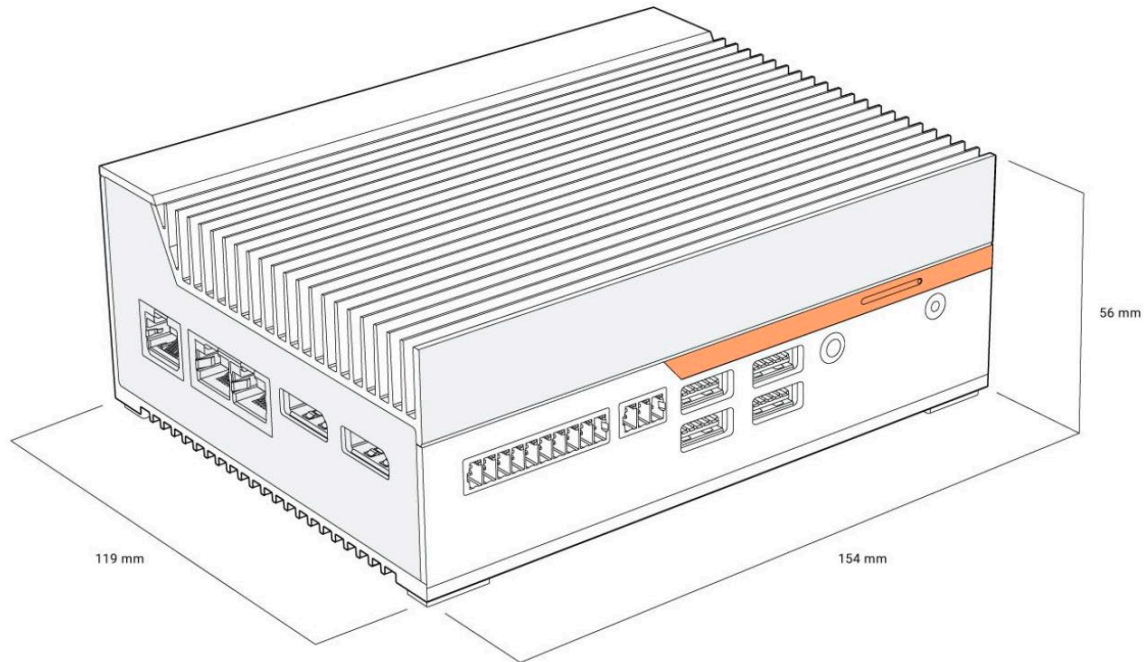

Length: 6.3 inches (160 mm)

Width: 4.7 inches (119 mm)

Depth: 2.2 inches (56 mm)

Weight: 3.0 pounds (1.36 kg)

Operating Temperature: -4°F to 158°F (-20°C to 70°C)

Enclosure: Ruggedized fanless design

11.3 SMART Controller Power Specifications

- Input Voltage: 9-36V DC power.
- 100-240V AC to 24V DC adapter is included with the SMART Controller.
- Typical power consumption in watts in various scenarios:

Powered down: 0.6 W

Idle, no PoE microphones attached: 6.4 W

Idle, one PoE microphone attached: 8.4 W

Streaming and analyzing one microphone: 9.5 W

Idle, two PoE microphones attached: 10.4 W

Streaming and analyzing two microphones: 12.2 W

Streaming/ analyzing one microphone, heater enabled: 15.2 W

Streaming/analyzing two microphones, heaters enabled: 17.9 W

NOTE: Power-down mode is controlled via Maintenance settings. See [Maintenance Tab](#). Use power-down mode to conserve energy when using solar panels or batteries.

11.4 SMART MIC-1 Dimensions

Length:	8.9 inches (226 mm)
Diameter:	3.0 inches (76 mm)
Weight:	1.4 pounds (0.64 kg)
Operating Temperature:	-4°F to 185°F (-20°C to 85°C)
Enclosure:	Fully weatherproof anodized aluminum

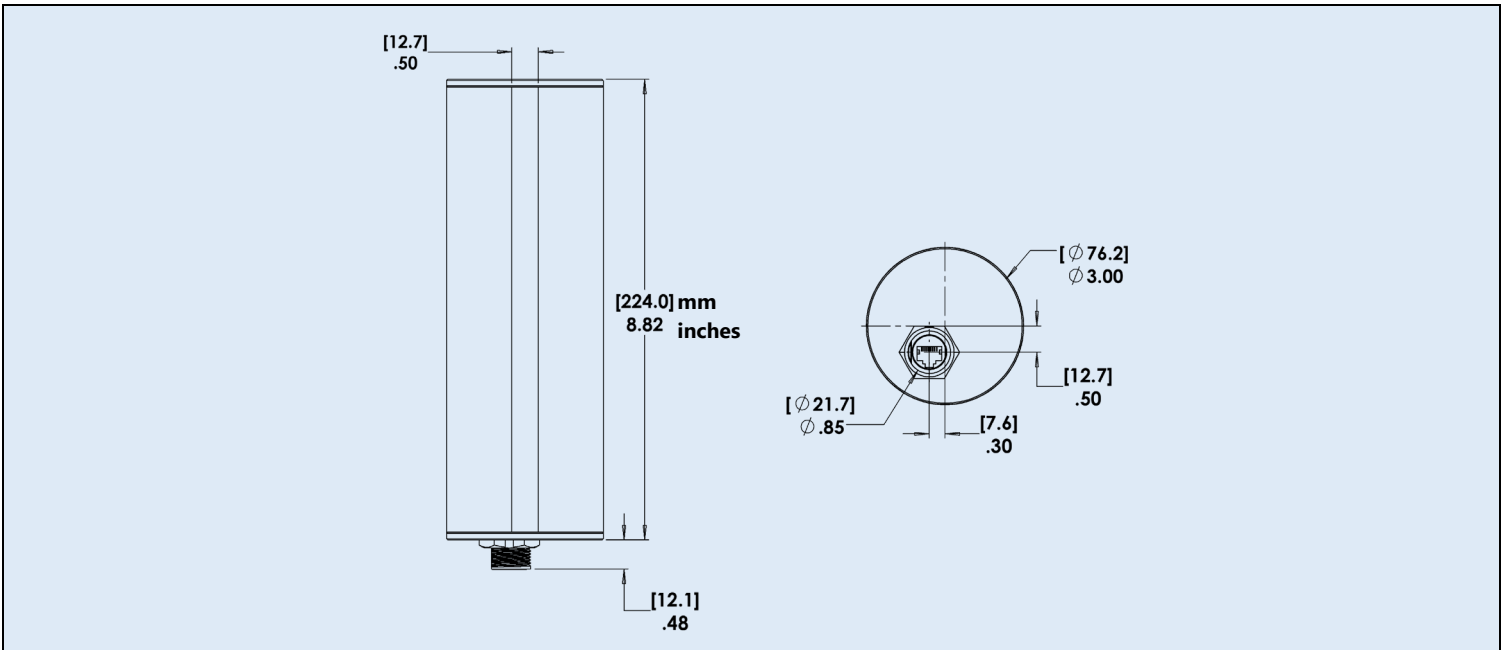

11.5 SMART MIC-1 Audio Specifications

Ultrasonic Sensors: 2, recordings made from strongest sensor

Ultrasonic Speaker: 40 kHz test tone

Condensation/ice Heater: 20°C above ambient temperature

Recording Format: 16-bit PCM WAV

Supported Sample Rates (kHz): 256, 384, and 500

Amplifier Gain: 0 or 12 dB

High Pass Filter: Selectable 2-pole at 8 or 16 kHz

Cable: Up to 100 meters CAT 5/6 cable

SMART Mic-1 On-axis Signal To Noise Ratio

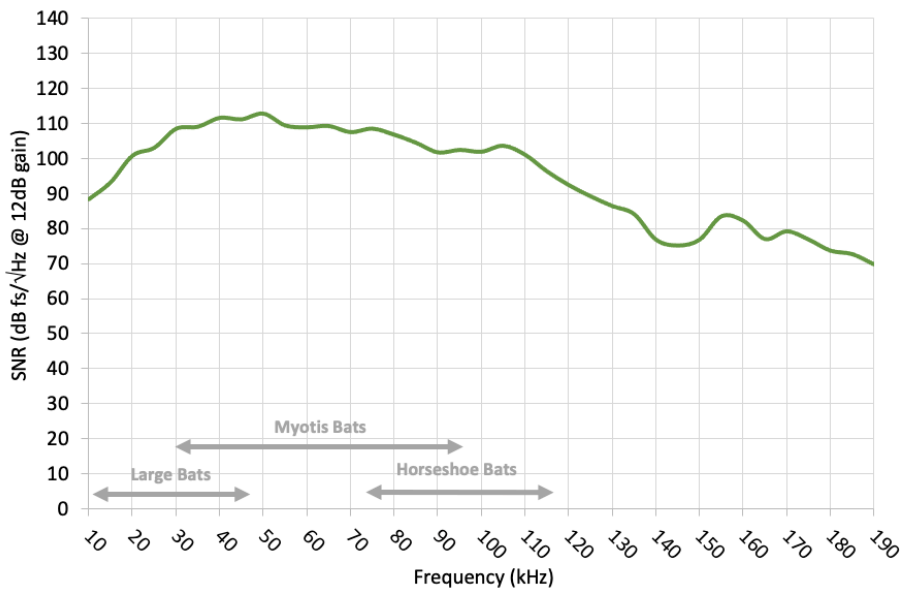

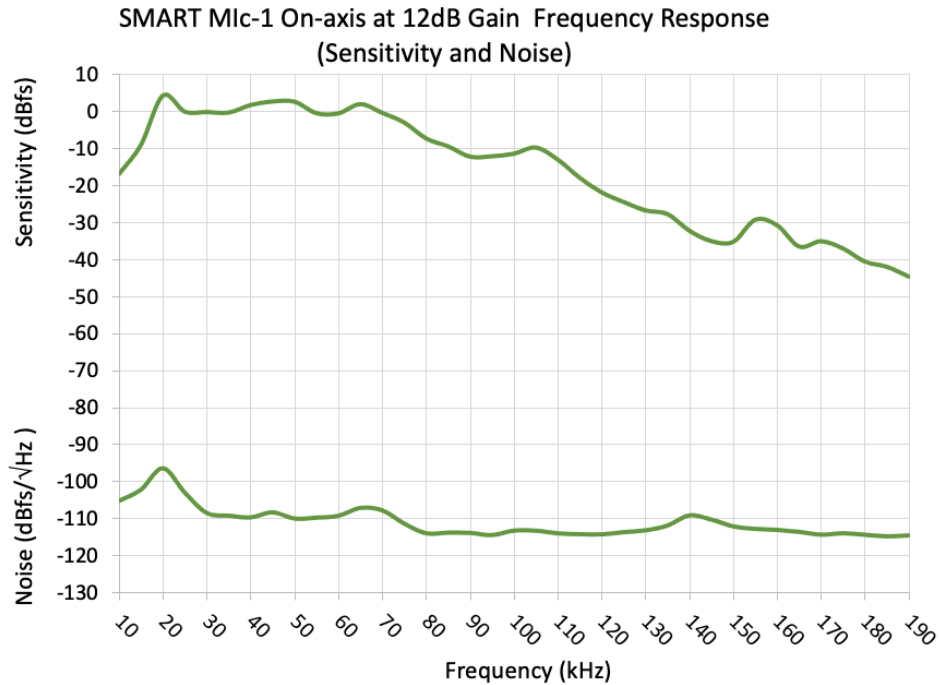

12 Additional Resources

12.1 Common Linux Command Lines

Linux command-lines can be sent to the SMART System via the SMART Internet Gateway or via direct monitor and keyboard connection.

Follow these instructions to execute direct command line functions.

1. Connect a video monitor and USB keyboard to the SMART Controller. No mouse is required.
2. At the first prompt, type the System name. If this has not been previously changed, the default is: "smart".
3. Press the Return key.
4. The next prompt will ask for a password. If the password has not been changed, the default is: "wildlife".
5. Press the Return key.
6. The next prompt is now waiting for a SMART command line.

Find the IP Address Being Broadcast by the SMART Controller WIFI

1. Type:
`ifconfig enp6s0`
2. Press Return.
 - The IP address is indicated next to "inet".

Restore the Default Netplan

1. Type:
`cd /usr/local/share/smart/config/OnLogic-Karbon-300`
2. At the next prompt type:
`sudo ./config.sh`
3. Press Return.
4. At the next prompt, type the network password.
 - The default netplan is now restored

12.2 Serial Port Configuration

The serial ports on the base model SMART Controller are "DTE" ports.

This means in RS-232, they are the male connectors which would be the "host" side of a connection rather than the "network" side of the connection.

- In most applications, a "null modem" cable or adapter (which swaps RX/TX lines) will be required to connect to another computer.
 - The SMART Controller supports RS-232, RS-422, and RS-485 on these ports.
 - By default, the ports are configured for RS-232.
 - The BIOS can be used to change the configuration to RS-422 or RS-485.
1. Plug in a monitor and keyboard, and press the ESC key while booting to enter the BIOS menu.
 2. From "Advanced" tab, go to the "NCT5524D Super IO Configuration" menu
 3. Change the mode for Serial Port 1 (ttyS0) or Serial Port 2 (ttyS1) from RS-232 to RS-422 (with or without termination resistor) and RS-485 (with or without termination resistor).

12.3 Bat Analysis Statistics

When Bat Analysis/Triggering is enabled, the SMART System uses Kaleidoscope Pro technology to generate statistics per event (bat pass).

Each triggered event (bat pass) is represented by a separate line in the .csv or serial output. Columns are used to describe statistics regarding the triggered audio event.

The following statistics are available in results.csv files and real-time serial output.

- **Prefix** This is the serial number or customized name of the SMART MIC-1 Device which has made the detection.
- **Date** Date of the event.
- **Time** Time of the event.
- **Duration** Duration of the event.
- **N** Total number of pulses detected. This is used to derive average values for the following 12 parameters:
- **Fc** Average characteristic frequency (kHz) - the body of the call is the portion of the call consisting of the flattest slope where the characteristic frequency is typically the frequency at the latest part of the call body.
- **Sc** Average characteristic slope (Octaves per Second) - this is the slope of the body of the call. Positive values correspond to decreasing frequency while negative values correspond to increasing frequency.
- **Fmax** Average maximum frequency (kHz) - the maximum frequency detected in the call.
- **Fmin** Average minimum frequency (kHz) - the minimum frequency detected in the call.
- **Fmean** Average mean frequency (kHz) - the time-weighted mean frequency of the call.
- **TBC** Average time between calls (ms) - if N above is greater than one, this is the average period of the calls from the start of one call to the start of the next.
- **Fk** Average frequency of the knee (kHz) - the frequency at the beginning of the call body.
- **Tk** Average time to the knee (ms) - the time from the beginning of the call to the beginning of the call body.
- **S1** Average initial slope (octaves per second) - the initial slope of the call.
- **Tc** Average time to the characteristic (ms) - the time from the beginning of the call to the end of the call body.

The following statistics are available in results.csv files only. (Not represented at serial output)

- **Pulses Classified** Number of pulses detected in the file that were identified to species.
- **Pulses Matching** Number of pulses matching the auto classification result.
- **Top1Match** Auto-ID classification result.
- **Top1Margin** Classification margin - this is an uncalibrated confidence score and should not be subject to much interpretation other than that within a given species, higher values are more confident than lower values.
- **Top2Match** First alternate.
- **Top2Margin**
- **Top3Match** Second alternate.
- **Top3Margin**

13 Terms Of Use

Customer agrees to be bound by the terms and conditions of Wildlife Acoustics, Inc., which can be found at <https://www.wildlifeacoustics.com/legal-documentation>. Customer further agrees that any End User is made aware of and bound by such terms and conditions.

14 Warranty and Disclosures

Except as specifically provided herein, Wildlife Acoustics makes no warranty of any kind, express or implied, with respect to this product.

Hardware Limited Warranty

Product	Components	Warranty Period
SMART System	SMART Controller	2 Years
	SMART MIC-1	5 Years

Wildlife Acoustics, Inc. Limited Warranty

HARDWARE: Wildlife Acoustics, Inc. ("WAI") warrants to the original end user ("Customer") that new WAI branded products will be free from defects in workmanship and materials, under normal use. Refer to the Hardware Limited Warranty table at the top of this page for the applicable warranty period from the original date of purchase.

WAI warrants refurbished WAI products, marked and sold as such, for ninety (90) days from the original purchase date.

SOFTWARE: WAI warrants to Customer that any WAI branded software will perform in substantial conformance to their schedule specifications for a period of ninety (90) days from the date of original purchase. WAI warrants the media containing software against failure during the warranty period. WAI makes no warranty or representation that the operation of the software products will be uninterrupted or error free, or that all defects in the software products will be corrected.

EXCLUSIONS: This warranty excludes (1) physical damage to the surface of the product, including cracks or scratches on the outside casing; (2) damage caused by misuse, neglect, improper installation or testing, unauthorized attempts to open, repair, or modify the product, or any other cause beyond the range of the intended use; (3) damage caused by accident, fire, power changes, other hazards, or acts of God; or (4) use of the product with any non-WAI device or service if such device or service causes the problem.

Any third party products, including software, included with WAI products are not covered by this WAI warranty and WAI makes no representations or warranties on behalf of such third parties. Any warranty on such products is from the supplier or licensor of the product.

No warranty is provided by WAI unless the product was purchased from an authorized distributor or authorized reseller.

EXCLUSIVE REMEDIES: Should a covered defect occur during the warranty period and you notify WAI, your sole and exclusive remedy shall be, at WAI's sole option and expense, to repair or replace the product or software. If WAI cannot reasonably repair nor replace then WAI may, in its sole discretion, refund the purchase price paid for the product. Replacement products or parts may be new or reconditioned or comparable versions of the defective item. WAI warrants any replaced or repaired product, part, or software for a period of ninety (90) days from shipment, or through the end of the original warranty, whichever is longer.

OBTAINING WARRANTY SERVICE: Customer should refer to the WAI website at www.wildlifeacoustics.com/support/contact-support for information on obtaining warranty service authorization. Methods for obtaining warranty service may vary depending on whether purchases were made from an authorized provider of WAI products or from WAI directly. All requests for warranty service authorization must be made within the applicable warranty period. Dated proof of original purchase will be required. Products or parts shipped by Customer to WAI must be sent postage-paid and packaged appropriately for safe shipment. WAI is not responsible for Customer products received without a warranty service authorization and may be rejected. Repaired or replacement products will be shipped to Customer at WAI expense. All products or parts that are replaced become the property of WAI. WAI shall not be responsible for Customer software, firmware, information, or memory data contained in, stored on, or integrated with any products returned to WAI for repair, whether under warranty or not. The repair and replacement process for products or parts in locations outside of the United States will vary depending on Customer's location.

WARRANTIES EXCLUSIVE: THE FOREGOING WARRANTIES AND REMEDIES ARE EXCLUSIVE AND IN LIEU OF ALL OTHER WARRANTIES, TERMS OR CONDITIONS, EXPRESS, IMPLIED OR STATUTORY, INCLUDING WARRANTIES OF MERCHANTABILITY, FITNESS FOR A PARTICULAR PURPOSE, ACCURACY, CORRESPONDENCE WITH DESCRIPTION, SATISFACTORY QUALITY AND NON-INFRINGEMENT, ALL OF WHICH ARE EXPRESSLY DISCLAIMED BY WAI AND ITS SUPPLIERS.

LIMITATIONS OF LIABILITY: NEITHER WAI NOR ITS SUPPLIERS SHALL BE LIABLE FOR INCIDENTAL, CONSEQUENTIAL, INDIRECT, SPECIAL, OR PUNITIVE DAMAGES OF ANY KIND, LOSS OF INFORMATION OR DATA, LOSS OF REVENUE, LOSS OF BUSINESS OR OTHER FINANCIAL LOSS ARISING OUT OF OR IN CONNECTION WITH THE SALE OR USE OF THIS PRODUCT, WHETHER BASED IN CONTRACT, TORT (INCLUDING NEGLIGENCE), STRICT PRODUCT LIABILITY OR ANY OTHER THEORY, EVEN IF WAI HAS BEEN ADVISED OF THE POSSIBILITY OF SUCH DAMAGES AND EVEN IF ANY LIMITED REMEDY SPECIFIED IN THIS LICENCE AGREEMENT IS DEEMED TO HAVE FAILED OF ITS ESSENTIAL PURPOSE. WAI'S ENTIRE LIABILITY SHALL BE LIMITED TO REPLACEMENT, REPAIR, OR REFUND OF THE PURCHASE PRICE PAID, AT WAI'S OPTION. IN NO EVENT SHALL WAI'S LIABILITY FOR ALL DAMAGES RELATED TO THE PURCHASE OF PRODUCT EXCEED THE AMOUNT PAID FOR THE APPLICABLE PRODUCT. THE FOREGOING LIMITATIONS WILL APPLY EVEN IF THE ABOVE STATED REMEDY FAILS OF ITS ESSENTIAL PURPOSE.

DISCLAIMER: Some countries, states, or provinces do not allow the exclusion or limitation of implied warranties or the limitation of incidental or consequential damages so the above limitations and exclusions may be limited in their application to you. When implied warranties may not be excluded in their entirety, they will be limited to the duration of the applicable written warranty. This warranty gives you specific legal rights; you may have other rights that may vary depending on local law. Your statutory rights are not affected.

GOVERNING LAW: This Limited Warranty shall be governed by the laws of the Commonwealth of Massachusetts, and by the laws of the United States, excluding their conflicts of laws principles. The United Nations Convention on Contracts for the International Sale of Goods is hereby excluded in its entirety from application to this Limited Warranty.

DECLARATION OF CONFORMITY (according to EN ISO/IEC 17050-1:2010)

No: **WAI20210407**

Manufacturer:

Wildlife Acoustics, Inc.
3 Mill and Main Place, Suite 210
Maynard, MA 01754
United States of America

Declares that the following product:

Product Name: SMART
Product Model Number: SMART MIC-1
Product Type: Ethernet Microphone

Conforms to the appropriate country standards and governing regulations listed below. As the manufacturer, we are fully responsible for the design and production of the above-mentioned equipment.

- (FCC) Code of Federal Regulations, Title 47, Part 15, Subpart B: Class A Device (2015): Radio Frequency Devices – Unintentional radiators
- AS CISP 11, (2017): Industrial, scientific and medical (ISM) radio-frequency equipment – electromagnetic disturbance characteristics – limits and methods of measurement, Class A
- EN 55011, (2016): Industrial, scientific and medical (ISM) radio-frequency equipment – Electromagnetic disturbance characteristics – Limits and methods of measurement, Class A
- ICES-003, (2020): Industry Canada, Interference-Causing Equipment Standard, Digital Apparatus, Class A
- EN 61326-1:2013 - Electrical Equipment for Measurement, Control and Laboratory use EMC Requirements
- EN 61000-4-2: Electromagnetic compatibility (EMC) Testing and measurement techniques - Electrostatic discharge immunity test; 4 kV Contact Discharge, 8 kV Air Discharge, 4 kV Horizontal and Vertical Coupling Planes (HCP and VCP, respectively)
- EN 61000-4-3: Electromagnetic compatibility (EMC) Testing and measurement techniques - Radiated, radiofrequency, electromagnetic field immunity test; 3 V/m, 80 to 1000 MHz; 3 V/m, 1.4 GHz to 2 GHz; 1 V/m, 2 GHz to 2.7 GHz
- EN 61000-4-4: Electromagnetic compatibility (EMC) Testing and measurement techniques - Electrical fast transient/burst immunity test; 1 kV on DC Mains; 1 kV on Data Cables
- EN 61000-4-5: Electromagnetic compatibility (EMC) Testing and measurement techniques - Surge immunity test; 1 kV on DC Mains
- EN 61000-4-6: Electromagnetic compatibility (EMC) Testing and measurement techniques - Immunity to conducted disturbances, induced by radio-frequency fields; 3 Vrms on DC Mains, 150 kHz to 80 MHz; 3 Vrms on Data Cables 150 kHz to 80 MHz
- **IEC 60529: Ingress Protection IP67**

Marking appears as follows:



This product was tested in a typical configuration.

Ian Agranat, President
Wildlife Acoustics, Inc.
April 7, 2021

ELECTROMAGNETIC INTERFERENCE

This equipment has been tested and found to comply with the limits for a Class A digital device, pursuant to Part 15 of the FCC Rules.

These limits are designed to provide reasonable protection against harmful interference when the equipment is operated in a commercial environment. This equipment generates, uses, and can radiate radio frequency energy and, if not installed and used in accordance with the instruction manual, may cause harmful interference to radio communications. Operation of this equipment in a residential area is likely to cause harmful interference in which case the user will be required to correct the interference at his own expense.

Changes or modifications not expressly approved by Wildlife Acoustics, Inc. could void the user's authority to operate the equipment.

Note: Use of ferrite clamped cables are required to comply with the Class A limits in part 15 of the FCC rules. A Fair-Rite 0443167251, 0431164281, or equivalent clamp must be placed on each cable near the microphone. This clamp is provided with all cables sold by Wildlife Acoustics.

PROHIBITION AGAINST EAVESDROPPING

United States law (Federal Communications Commission Part 15 Section 15.9) states "Except for the operations of law enforcement officers conducted under lawful authority, no person shall use, either directly or indirectly, a device operated pursuant to the provisions of this Part for the purpose of overhearing or recording the private conversations of others unless such use is authorized by all of the parties engaging in the conversation."

You are responsible for complying with all applicable laws within your jurisdiction

PRODUCT DOCUMENTATION

©2015-2024 Wildlife Acoustics, Inc. All Rights Reserved.

This documentation may not be reproduced or distributed in any form or by any means, graphic, electronic, or mechanical, including but not limited to photocopying, scanning, recording, taping, e-mailing, or storing in information storage and retrieval Systems without the written permission of Wildlife Acoustics. Products that are referenced in this document such as Microsoft Windows® may be trademarks and/or registered trademarks of their respective owners. Wildlife Acoustics makes no claim to these trademarks. While every precaution has been taken in the preparation of this document, individually, as a series, in whole, or in part, Wildlife Acoustics, the publisher, and the author assume no responsibility for errors or omissions, including any damages resulting from the express or implied application of information contained in this document or from the use of products, services, or programs that may accompany it. In no event shall Wildlife Acoustics, publishers, authors, or editors of this guide be liable for any loss of profit or any other commercial damage caused or alleged to have been caused directly or indirectly by this document.

SMART

SONG METER WITH ANALYSIS AND REMOTE

User Guide

©2024 Wildlife Acoustics, Inc. All Rights Reserved.

Wildlife Acoustics, Song Meter and Kaleidoscope are registered with the U.S. Patent and Trademark Office.

All other trademarks are the property of their respective owners.

The SMART System is covered under the following patents:

US 10911854, 8995230

EP 2877820, 1661123, 008841142

CA 62986988

GB 2559839, 6188390, 6188391, 6188392 & 6188393

AU 202210794, 202210795, 202210796, 202210797

Wildlife Acoustics, Inc.

3 Mill and Main Place, Suite 110

Maynard, MA 01754

(978) 369-5225 or toll-free in the U.S. (888) 733-0200

www.wildlifeacoustics.com



WILDLIFE

ACOUSTICS